

---

Alberta Landholder's Guide to

---

# Wildlife Friendly FENCING



# ACKNOWLEDGEMENTS



Many land and wildlife specialists, ranchers, and landholders generously offered their insights and experience for this guide. This handbook builds on two previous publications by this author, which are used with permission: *A Landowner's Guide to Wildlife Friendly Fences*, written for and published by Montana Fish, Wildlife and Parks (2012) and *A Landowner's Guide to Fences and Wildlife*, published by the Wyoming Wildlife Foundation (2015). This new Alberta handbook is revised and updated, featuring the practical experience of Alberta landholders and resource managers who have tested and adopted wildlife friendlier fencing.

Special thanks to everyone who contributed insights, research, photographs, and manuscript reviews. Staff with Alberta Environment and Parks and Alberta Conservation Association provided guidance, support, information, writing of short sections, and extensive reviews. Paul Jones and Brad Downey (ACA) spearheaded the creation of this Alberta handbook and nurtured it from start to finish. Jeff Bectell, Tony and Lorraine Bruder, John Cross, Helen and Clarence Cyr, Tyler Johns, Joel Nicholson, T.J. Schwanky, Jeff Smith, Gerry Taillieu, and Norm Ward shared their experiences for the first-hand stories found throughout the document. Deep thanks also to Ed Jenne and Kristen Rumbolt Miller for their illustrations, and to the many photographers who generously donated their photos for use in the guide. This guide was only made possible because of the talents and creativity of everyone involved.

For questions, please contact Alberta Conservation Association at [info@ab-conservation.com](mailto:info@ab-conservation.com) or 1-877-969-9091.

---

This project was undertaken with the financial support of:  
Ce projet a été réalisé avec l'appui financier de :



Environment and  
Climate Change Canada

Environnement et  
Changement climatique Canada

## **AUTHOR**

Christine Paige, M.Sc.  
Ravenworks Ecology, Driggs, ID  
[wanderofftrail@gmail.com](mailto:wanderofftrail@gmail.com)

## **GRAPHIC DESIGN**

Alberta Conservation Association

## **ILLUSTRATIONS**

E.R. Jenne Illustration  
Missoula, MT  
[edjenne@earthlink.net](mailto:edjenne@earthlink.net)

Kristen Rumbolt Miller  
Lethbridge, AB

## **CITATION**

Paige, C. 2020. Alberta Landholder's Guide to Wildlife Friendly Fencing. Alberta Conservation Association, Sherwood Park, Alberta. 68 pp.

# Table of CONTENTS

Wildlife and Fences .....	1
Problem Fences .....	3
Wildlife Friendlier Fences .....	6
Friendlier Designs .....	10
Remedies for Existing Fences.....	49
Acreage Fences.....	52
If You Must Exclude .....	55
Deterring Predators .....	61
Getting Help .....	65
Sources.....	66



Photo: Mark Gocke



Photo: TJ Schwanky

# Wildlife and FENCES

## Why build fences with wildlife in mind?

**Countless kilometers of fence crisscross the West like strands of a spider's web.** Fences are important tools for controlling livestock and deterring trespass. They define and separate ranches and farms, outline property boundaries, enclose pastures and rangelands, and prevent livestock from straying onto highways. **Despite Alberta's vast spaces, the cumulative length of fences found in southern Alberta and northeastern Montana would circle the earth eight times** (Jones et al. 2019).

Fences also create hazards and barriers for wildlife, from big game animals to birds. Fences can block or hinder daily wildlife movements, seasonal migrations, and access to forage and water. Wildlife may avoid areas with too many fences to negotiate – for example, pronghorn choose seasonal ranges with lower fence densities (Sheldon 2005, Jones et al. 2019). When animals collide or tangle in fences they can be injured or killed, and wildlife damage to fences can be costly and frustrating for landholders.

Yet not all fences create problems for wild animals. By tailoring fence design and placement, you can prevent wildlife injuries and decrease damage to your fence. Many of these methods are low-cost or can save money in the long run by reducing the need for future fence repair.

This guide will help you construct and modify fences and crossings that are friendlier to wildlife while still meeting fencing needs. It will also help you with sources for technical assistance and possible cost-share opportunities.

Many wildlife friendly fence designs are easy, low-cost, or save money and labor by reducing future fence repair.

## ALBERTA FENCE LAW

In Alberta, if you own livestock it's your responsibility to fence them in, not your neighbours' responsibility to fence them out. Fencing falls under several pieces of legislation in Alberta and places the responsibility for the control or confinement of livestock on the occupant.

### *Stray Animals Act*

**A landowner is responsible for keeping his/her land properly fenced and livestock contained. If damage is caused by cattle trespassing onto another property, the owner of the cattle is responsible for the damage. The following are excerpts taken from the *Stray Animals Act* (Alberta Queen's Printer 2010):**

Section 37(1) - No person shall permit or allow any livestock owned by the person or in the person's possession to trespass on land owned by another person.

Section 37(2) - No person shall permit or allow any livestock owned by the person or in the person's possession to be on a highway unless it is in the person's or another person's direct and continuous charge and the person or that other person is competent to control the livestock.

### *Public Lands Act*

Grazing dispositions occur on more than 8 million acres of public land in Alberta. Dispositions are fenced public lands identified and allocated for short-term or long-term grazing use. Under the *Public Lands Act* (Alberta Queen's Printer 2020) grazing disposition holders must adequately fence the disposition boundary to confine their livestock. Grazing lease fencing is legislated under the *Public Lands Act* but fencing obligations for other types of dispositions are covered in their contract or disposition documents.

Under the *Public Lands Act*, "livestock" is defined as horses, sheep, cattle and, to the extent permitted by the regulations, bison.

According to Section 53(3) the holder of a grazing disposition must:

- confine the livestock to the land under the disposition and any other land that is controlled by the holder and grazed in conjunction with that land, and
- erect any fences and cattle guards that are necessary to ensure compliance with clause (a).

### *Line Fence Act*

Landowners are obligated by the *Line Fence Act* (Alberta Queen's Printer 2016) to make arrangements with the adjoining owner/occupant regarding the purchase and maintenance responsibilities of shared perimeter fences. **If both occupants benefit from the fence, they should share the costs, which include the costs for erection, maintenance, and repair of the fence.** In this legislation, benefit is determined by having livestock on the land. If one landowner has needs above and beyond what would be normal, they are responsible for the additional cost. Refer to the *Line Fence Act* for further obligations regarding adjoining owners and settlement of disputes (<http://www.qp.alberta.ca/documents/Acts/L13.pdf>).

Under Section 1.1(1) of the *Line Fence Act*, "livestock" means cattle, horses, bison, sheep, swine including wild boar, goats and diversified livestock animals within the meaning of the *Livestock Industry Diversification Act*.

### *Other Regulations*

Check with your county and municipality offices for any local ordinances or regulations specific to fences. In addition, if your fence adjoins a provincial highway, check with Alberta Ministry of Transportation regarding highway right-of-way fencing specifications and options for modifying fences for wildlife.



Photo: ACA, Paul Jones

# Problem FENCES

**Although deer, elk, moose, mountain sheep, and pronghorn are all capable of jumping fences, in a variety of situations they can become injured or entangled.**

Wire strands can readily snag animals and tangle legs, especially if wires are loose or spaced too closely together.

Animals can be hindered by deep snow or steep slopes, and young, pregnant, or winter-stressed animals may have a particularly difficult time clearing fences. Deer, elk and other wildlife often bear scars from wire barbs. A torn ligament, strained leg, or infection can weaken an animal's chance of survival, and if animals can't pull free at all, they slowly die of trauma, dehydration, or predation.

Some fences, especially page wire fence, can be a complete barrier to fawns and calves even if adults can still jump over. Separated from their mothers and stranded from the herd, the youngsters curl up and die of exposure and dehydration. Page wire can snare and strangle medium-sized animals and livestock if they push their heads through the wire mesh and may

block animals such as bears and bobcats that are too large to slip through.

If page wire is topped with one or more strands of barbed wire the fence becomes a complete barrier, especially for fawns, calves, pronghorn, and other animals that are incapable or unwilling to jump over. Animals trying to leap a page wire or barbed wire fence are even more likely to tangle a leg between the top barbed wire and the stiff page wire. In urban areas, fences topped with barbs or pointed spikes, such as decorative iron fences, can trap or impale leaping deer and other animals.

Large and small low-flying birds may also collide with fences and break wings, impale themselves on barbs, or tangle in wires. Ducks, geese, cranes, swans, grouse, hawks, and owls are especially vulnerable. Waterfowl fly into fences that run near or across waterways, and hawks and owls may careen into fences when swooping in on prey.



Photo: Mark Gocke



Photo: Steve Primm

Winter-stressed, pregnant, and young animals may especially have trouble clearing fences. An injury or infection from tangling with fences can weaken an animal's chance of survival. If animals can't pull free at all, they die of trauma, dehydration, or predation.



Photo: Sheila Lamb



Photo: Randy Lee

# Problem FENCES

## What kinds of fences create problems for wildlife?

Fences that:

- are too high to jump;
- are too low to crawl under;
- have loose or broken wires;
- have wires spaced too closely together;
- can impale or snag a leaping animal;
- are difficult for running animals or birds to see;
- create a complete barrier.



After crossing a highway, a black bear desperately searches for a way through a page wire fence, finally climbing a power pole to leap over.



Photo: Chris Mayne





## The Bottom Line: Hard Numbers

**Researchers at Utah State University completed a study of wildlife mortality along more than 650 miles (1,046 km) of fences in the rangelands of northeastern Utah and northwestern Colorado (Harrington 2005, Harrington and Conover 2006).** By driving and walking fence lines over two seasons, they tallied the number and ages of mule deer, pronghorn, and elk carcasses they found caught in fences and lying next to fences. They also studied which fence types caused the most problems. Here are their key findings.

### Snared and Entangled

- On average, one ungulate per year was found tangled for every 2.5 miles (4 km) of fence.
- Most animals (69% of juveniles and 77% of adults) died by getting caught in the top two wires while trying to jump a fence.
- Juveniles are 8 times more likely to die in fences than adults.
- Mortalities peaked during August, when fawns were weaned.
- Page wire fence topped with a single strand of barbed wire was the most lethal fence type, as it easily snared and tangled legs between the barbed wire and rigid page wire.
- 70% of all mortalities were on fences taller than 39" (1 m).

### Blocked and Stranded

- Where ungulates were found dead next to, but not in fences, on average 2.08 ungulates die for every mile of fence (1.3 ungulates/km).
- 90% of these carcasses found near fences were fawns lying in a curled position – probably separated from their mothers when they could not cross.
- Most of these indirect mortalities were found next to page wire fences.

*Elk, deer, and other ungulates often die if their legs tangle in wire fences. Page wire topped with barbed wire is the most lethal type of fence, especially for young wild ungulates.*

**TIP:** If trying to rescue a tangled and struggling animal, cover its head with a cloth or coat to help calm the animal.



# Wildlife friendlier FENCES

## Getting Started

**The best situation for wildlife is open habitat with no fences at all. Wherever possible, remove obsolete fences that are no longer needed.**

### WHEN YOU DESIGN YOUR FENCE, CONSIDER:

- purpose of the fence;
- topography – hills, gullies, streams, and wetlands;
- species of wildlife present;
- daily or seasonal wildlife movements in the area;
- presence of water, food, and cover for wildlife;
- presence of young animals;
- problem fence spots.

Most fences can be designed or modified to allow easier passage for wildlife.

Where you need to fence, less fence is better. Established fences can be modified to allow easier passage, and new fence can be designed with wildlife in mind.

To get started, consider your needs and create a plan. You can tailor any of the designs in this guide to your specific needs.

### First consider these questions:

#### 1. What is the purpose of the fence?

Do you need to mark a boundary? Deter trespass? Enclose or exclude livestock? If your fence is for livestock, what kind, in what seasons, and for how long?

*Your purpose should determine your fence design and placement.*

**2. What is the topography?** Are you fencing on hills, in rocky country where posts cannot be driven, or near or across streams or wetlands? *Design your fence to avoid creating traps or barriers for wildlife.*

**3. Which wildlife species are in your area and when?** *Build fence or crossings that both young and adult animals can negotiate.*

**4. Where do wildlife move daily and seasonally in the area?** Is there water nearby? Do wildlife migrate through to winter or breeding areas? Do animals calve, bed, or nest nearby? *Allow movement through natural corridors and access to water and habitat.*

**5. Are there sections of fence that you repair often?** *Target the placement of fence modifications to reduce maintenance time and associated costs.*



Illustration: E.R. Jenne Illustration

## Fence and Crossing Placement

### Placement of fences is just as important as the type of fence used.

Fencing need not restrict wildlife movement everywhere on your property. Wherever possible, design your fence to provide wildlife free travel to important habitats and corridors, as well as access to water. Wetlands and riparian habitats are especially important for all wildlife.

Watch for daily and seasonal wildlife movement patterns and look for trails. Use impenetrable, special purpose fence only in specific areas where it is critical, such as calving or lambing pastures, haystacks, gardens, orchards, kids' play areas or kennels.

Design property boundary fence so wildlife can easily cross, or with gaps, crossings, or lay-down sections for wildlife passage whenever and wherever livestock are not present.

Work with your land's topography. Swales, gullies, ridges, and stream corridors can funnel wildlife through an area – keep these open to allow wildlife passage and avoid topography traps.

A fence of any height is more difficult to cross when placed across a steep slope or next to a deep ditch. As ground slope increases, the height an animal must jump to clear the fence increases considerably. For instance, a 42" (1.07 m) fence may be passable on level ground, but a slope of only 10% increases the effective fence height to 48.6" (1.23 m); a slope of 30% increases the effective height to 62" (1.57 m), and on a 50% slope animals encounter an obstacle 75" (1.91 m) high. Fences on steep slopes become nearly impossible for animals to jump without injury.

*Tailor your fences to specific needs and allow wildlife access to water, important habitats, and travel corridors.*



Photo: Christine Paige

### GOOD FENCE PLACEMENT TIPS

- Look for wildlife trails and watch for seasonal patterns.
- Provide wildlife access to riparian habitats, water holes, and other high-quality habitats.
- Provide passage along swales, gullies, ridges, and stream corridors.
- Use the appropriate fence design for each activity.
- On slopes and in natural travel corridors, plan for wildlife openings and crossings.



Photo: Christine Paige

## SLOPE INCREASES BARRIER

Illustration: Kristen Rumbolt Miller

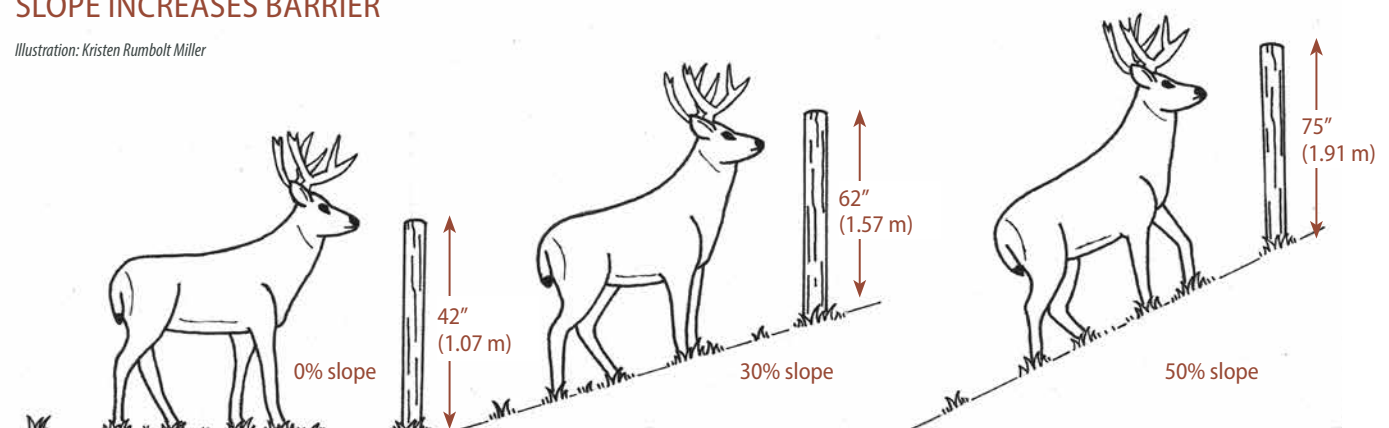

Since 1997, Alberta Conservation Association (ACA) has worked to protect and enhance Alberta's natural heritage for all to enjoy. One important tool in ACA's conservation toolbox is to deploy wildlife friendlier fencing on ACA Conservation Sites to allow wildlife freedom to move.



## Wildlife Friendly Fence: Key Management Tool on Alberta Conservation Sites

ACA currently manages 344 Conservation Sites throughout the province, which include more than 210,000 acres of titled and Crown land. The Conservation Site Management Program targets key wildlife and riparian habitats for protection through title purchase and leases, often in partnership with other private landholders, provincial and Crown lands, and other NGOs. Conservation Sites not only conserve vital habitats, but provide opportunities to the public for hunting, fishing, berry picking, bird watching, photography, and other sustainable outdoor recreation.

Most of these sites are relatively small, a few hundred acres each, and so fencing and good relations with neighbors is always a consideration. For each Conservation Site, ACA develops a management plan with goals for biodiversity, land use, recreation, and the infrastructure needed for habitat

restoration and management. Fences are important tools to manage habitat and access, so all existing fences are mapped and evaluated. Wherever possible, ACA removes obsolete fences and modifies necessary fences to wildlife friendly specifications. This may mean pulling out interior pasture fences, using moveable electric fence for grazing and grass management, and altering page wire and 5-wire barbed wire fence to wildlife friendly specifications.

ACA's Riparian Conservation Program works with landholders to protect important river, stream, and wetland habitats for fish and wildlife. Along the North Raven and Raven Rivers, for example, ACA staff have been working with landholders to protect the riparian habitat and trout fishery, using exclusion fencing as one tool.

"Many landholders have implemented wildlife friendly fences to exclude their livestock from the riparian buffer," says Erin VanderMarel, ACA's Central Region Riparian Coordinator. "These fences include barbless top and bottom wire with specific height measurements or even single-strand electric fences in some cases." The fences protect the streambanks from livestock but allow wildlife free passage.

In the prairies, ACA has partnered with Alberta Fish and Game Association (AFGA) on ACA Conservation Sites to alter fences for pronghorn. ACA provides new wire and AFGA volunteers do the work, replacing page wire fences and 5-strand barbed wire fence with a fence friendlier to pronghorn. The end result is a fence no higher than 42" and with double-stranded smooth wire at 18" above the ground to allow pronghorn to slip under easily without injury.

ACA's recently acquired Chinook Conservation Site near Medicine Hat encompasses 464 acres of creek bottom, coulee breaks, and grassland prairie. Secured in partnership with Environment and Climate Change Canada, AFGA, Pheasants Forever Chinook and Calgary Chapters, and Wild Elk Federation, the site provides habitat for upland game birds as well as mule deer and pronghorn. To benefit wildlife, several fences were removed altogether, and others were modified by re-spacing wires and replacing the bottom barbed wire with double-stranded smooth wire.

"Sometimes our volunteers see the results right before their eyes with wildlife crossing right after they've fixed a fence," says Tyler Johns, Biologist with the ACA Land Management Program. "Our eventual goal is to modify all the fences that we can on ACA properties across the province."



Photos: ACA, Paul Jones

# Friendlier DESIGNS

## A Friendlier Fence

**A fence that is friendlier to wildlife should:**

- **Allow animals to jump over and crawl under easily without injury;**
- **Be highly visible for both ungulates and birds.**

You can combine or tailor many of the ideas presented in this guide for your specific situation. The top wire or rail should be low enough for adult animals to jump over, preferably 40" (1.02 m) or less, and no more than 42" (1.07 m) high. The distance between the top two wires should be no less than 12" (30 cm) apart. Deer and elk easily tangle their back legs if the top wires are closer together.

The bottom wire or rail should be high enough for pronghorn and young wild ungulates to crawl under. The bottom wire should be at least 18" (46 cm) from the ground (Jones et al. 2018). Take advantage of small dips, swales, and gullies to provide a slightly larger gap below the fence and allow animals to pass under easily. Many cattle ranchers have found that although a small calf may slip under the higher bottom wire, they can also easily slip back again to mom and not be stranded on the wrong side of the fence.

Increasing visibility using a top rail, high-visibility poly-wire, flagging, or other markers can help ungulates and birds better avoid or navigate fences. Using

double-stranded smooth wire (barbless twisted wire) for the top and bottom strands will prevent snagging and injuries.

Use electric tape or braid only for temporary applications. It should be removed or lowered to the ground when livestock are not present.

In some situations, fence stays can help maintain distance between strands, prevent sagging, and reduce the chance of entanglement. However, wire stays are easily bent over, collapsing the fence and creating a three-dimensional hazard, and need to be regularly maintained. An alternative is a stiff plastic or composite stay or fiberglass post that flexes but maintains its shape. If stays protrude above or below the fence wires, they also effectively reduce the area animals can pass over or under the fence.

In wildlife movement areas, drop-down fence, lay-down fence, or other crossings can be incorporated into sections of fence for seasonal wildlife passage.

**Sound husbandry practices go hand in hand with wildlife friendlier fences. Livestock that have good forage and the security and companionship they want are less likely to test or challenge fences.**

### THE WILDLIFE FRIENDLIER FENCE: A LIVESTOCK/WILDLIFE COMPROMISE

These standards will control cattle in most situations and allow for easier wildlife passage. Fences should be low enough for adult animals to jump, high enough for wildlife to crawl under and minimize the chance of tangling. We recommend:

- A top wire or rail preferably no more than 40" (1.02 m) and a maximum of 42" (1.07 m) above the ground;
- At least 12" (30 cm) between the top two wires;
- A bottom wire or rail at least 18" (46 cm) above the ground;
- Smooth wire or rail for the top, smooth wire on bottom;
- No vertical stays. If used, consider stiff plastic or composite stays, or regularly maintain wire stays that are easily bent;
- Posts at 16.5-foot (5 m) intervals;
- Gates, drop-downs, or other passages where wild animals concentrate and cross.

## A FRIENDLIER FENCE FOR WILDLIFE

The friendliest fences are very visible and allow wild animals to easily jump over or slip under the wires or rails.

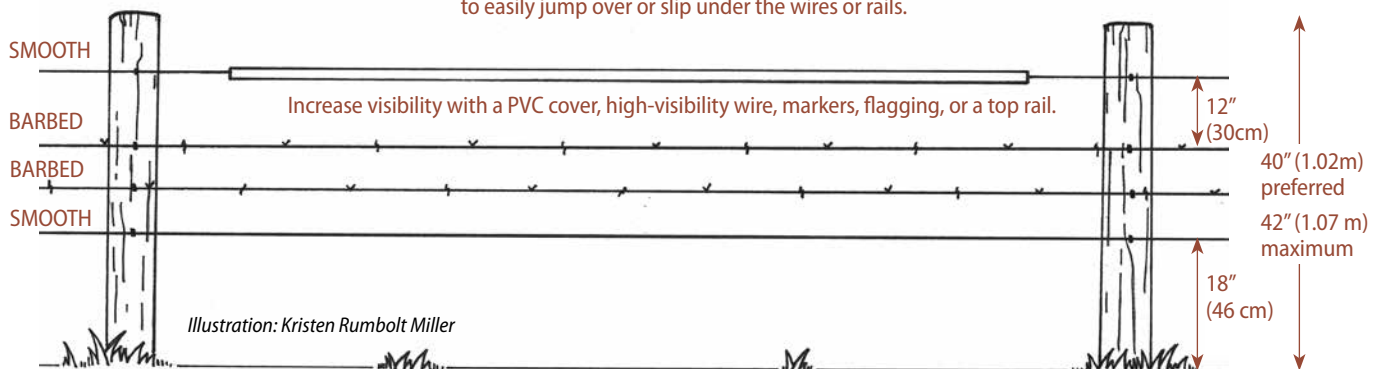

## Visibility

**Running animals and low-flying birds may not see a wire fence clearly against the landscape.** Making a fence highly visible prevents collisions and can help animals judge the height of a fence for jumping.

One solution is a top rail. A rounded rail will shed snow more easily: heavy snow buildup can sometimes deter elk and deer from crossing. For wire fences, an inexpensive modification is to slip small diameter PVC pipe over the top wire—research has found that the PVC does not deter wildlife from jumping the fence (Jones et al. 2020).

Smooth wire fences, especially high-tensile wire, may be essentially invisible to animals. These can be made more visible by adding fence markers or highly visible polywire or polytape on the top strand. Double-stranded smooth wire is more visible than a single wire strand, and high-visibility wire is available in many forms – tape, braid and polymer-coated wire – which can be electrified if needed. White wire is the most visible in summer, but black and white wire or tape makes the fence more visible against both summer vegetation and snow.

High visibility helps animals avoid and negotiate fences. It is especially important in grasslands and near creeks and wetlands to protect low-flying birds, such as grouse, owls, and swans. Rails, PVC pipe, flagging, or black and white wire or tape can all make fences more visible.

Photo: Joel Nicholson



Photo: ACA, Paul Jones

# Friendlier DESIGNS

## Fence Flags for Grouse and Other Birds

**Fence flags or markers dramatically increase visibility of wire fences for wildlife, especially birds, and help animals avoid and negotiate fences.**

Research on sage-grouse and other prairie grouse has shown that fence collisions are common and widespread, especially near breeding areas. Grouse fly fast and low into their mating areas (called “leks”) just before dawn and, in the dim light, are vulnerable to colliding with nearby fences.

However, marking fence for visibility can dramatically reduce collisions by 70% to 83% (Christiansen 2009; Stevens et al. 2012b.)

Research has shown that fence markers can reduce sage-grouse fence collisions by 70% to more than 80%.



Photo: Jeremy Roberts, conservationmedia.com

### DIY VISIBILITY MARKERS FOR WIRE FENCE

For barbed or page wire fence:

- Cut several 12 ft (3.65 m) strips of “undersill” or trim strips of white vinyl siding, available at home hardware centers.
- Cut strips into 3” (7-8 cm) pieces. Use tin snips for small projects or use a 10” (25 cm) miter saw with a 200-tooth blade to cut up to 16 pieces at a time for larger projects.
- One 12 ft (3.65 m) siding strip yields 48 pieces.
- For extra visibility, add reflective tape to both sides of the markers, which increases detection in low light. Or use both black and white markers for visibility against snow and vegetation.
- Snap pieces onto fence wires – they are held in place between barbs.

For each rod (16.5 ft; 5 m) of fence a minimum of two markers with reflective tape placed on the top wire is effective. Or, one can alternate four pieces of black and white markers on the top wire. Marking a lower or bottom wire will also increase visibility for pronghorn and other wildlife.

For smooth wire fence:

- To keep the vinyl siding markers from sliding, crimp a ferrule, twist a small spring, or tighten a UV-resistant zip-tie (tie-wrap) onto the wire on each side of the marker. Although this adds time to installation, it keeps the markers in place. Crimping the marker itself causes the marker to wear and break.
- An alternative is to make flags from reflective tape that can adhere to the wire (note, however, that reflective tape will conduct power on a hot wire.)
- Some commercially made markers available online or in ranch supply outlets may work better on smooth wire.
- Place a minimum of two flags per rod of fence on the top wire; or up to four on the top wire and three on the middle or bottom wire.



## DURABLE MARKERS ON WIRE FENCE

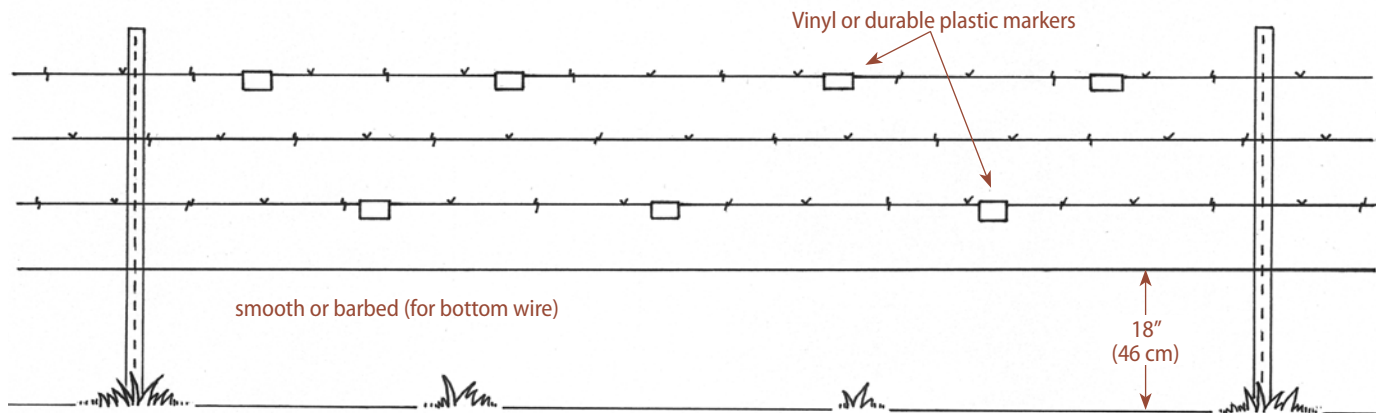

Illustration: Kristen Rumbolt Miller

**Not every mile of fence needs to be marked for sage grouse.** Marking is most important where there are high densities of birds -- within 1.2 mi (2 km) of a lek and in wintering areas. Sage-grouse are also most vulnerable to collisions in open, flat, or rolling country, and in areas with more fences [ $>2.6$  mi/m<sup>2</sup> of fence ( $>1$  km/km<sup>2</sup>); Stevens et al. 2012a, 2012b].

A relatively inexpensive and durable marking technique uses 3" (7-8 cm) flags cut from vinyl "undersill" or trim siding strips. The undersill siding has a lip that can be snapped onto barbed wire fence, with the barbs keeping the markers from sliding. (See BOX page 12 for how to make your own.)

As an alternative, commercially produced fence markers can be purchased through a number of retail and mail order outlets. For example, Pexco LLC sells a durable version in black or white made with rigid plastic and a reflective strip, available at [www.pexco.com](http://www.pexco.com). Fly Safe markers are made of polypropylene plastic in yellow with a reflective strip, available at [www.flysafellc.com](http://www.flysafellc.com).

While marking the top wire only is effective for grouse, adding markers to lower wires may also help pronghorn and other wildlife that slip under fences.



Photo: Conservation Media



Photo: Christine Paige



Durable and lightweight fence markers can be cut from strips of vinyl siding trim. The trim strip has a lip that easily snaps onto fence wires. Commercial markers are also available, such as this version from Pexco.com.

Photo: Pexco LLC, Pexco.com

In early spring, sage-grouse gather at lek sites—traditional arenas where males strut, court females, and battle other males. Just before dawn, the lek comes alive with the soft swish-swish, ploop-ploop sounds of displaying males. But as birds approach the lek, often flying in just above the sagebrush, they can collide with barbed wire fences, which are nearly invisible in low light. Research studies have shown that increasing the visibility of fences is one simple and effective way to benefit grouse.



Photo: Christina Paige

## Modifying Fences Benefits Endangered Sage-grouse

With fewer than 100 individuals left in the province, the greater sage-grouse is one of Alberta's most imperiled species. Entirely dependent on sagebrush habitats, sage-grouse occur in less than 10% of their historic Alberta range, restricted to the southeastern corner of the province. Populations have been in decline for some time, and in 2000 the sage-grouse was listed as endangered both in the province and federally.

With the input and involvement of stakeholders, the province developed a sage-grouse recovery strategy and Alberta Environment and Parks (AEP) launched a multi-pronged program to stabilize and restore grouse numbers. The recovery program works on projects that conserve and enhance habitat, augment the population, and reduce mortality.

"A single hen killed by a fence has a huge impact on the Alberta population," says Joel Nicholson, Senior Wildlife Biologist for AEP and chair of the Alberta Sage-grouse Recovery Team. "There are only three leks still active in Alberta and this is why we place lots of focus on reducing mortality."

Adding highly visible markers to wire fences is one simple, inexpensive, and effective strategy—fence visibility markers can reduce collisions by more than 80%.

Partnering with Environment and Climate Change Canada (ECCC, formerly Environment Canada) and Alberta Conservation Association (ACA), the recovery team works with willing landholders to alter their fences to benefit sage-grouse. They first prioritized sites for mitigation by using a model from the US-based Sage Grouse Initiative to map high-risk fences near leks.

So far, the team has improved 8 miles (nearly 13 km) of high priority fences and plans more. They reconstruct fences to wildlife friendlier standards, installing smooth wire on top and bottom with two strands of barbed wire between, and then clip on high-visibility markers every 3' (1 m). Although many fence marking projects for sage-grouse use DIY markers made from vinyl undersill siding (see pages 12-13), AEP uses a more durable commercial version made with rigid plastic and a reflective strip, available from Pexco LLC at [www.pexco.com](http://www.pexco.com).



Photo: Joel Nicholson

With such a perilously small sage-grouse population hanging on in Alberta, everything landholders can do to enhance sagebrush habitat will benefit the grouse. In addition to a variety of habitat projects, the recovery team helps landholders remove and alter predator attractants in high priority habitat.

"All types of human-made structures in sagebrush landscapes can become oases for predators and population sinks for grouse" explains Nicholson. For instance, dilapidated buildings and hedges around crumbling farmsteads host rodents that lure in everything from coyotes to skunks to owls, so the team has worked to eliminate some of these predator hotspots on both public and private lands. In addition, wood fence posts and rails serve as perches for raptors and ravens. On wood posts and rails, commercial perch deterrents, such as metal cones and several types of metal spike arrays, can reduce raptor perching to some extent. Metal t-posts are not recommended in sage-grouse country as an alternative to wood as they are less visible to grouse and increase the risk of collisions.

Landholders who want to help enhance sage-grouse habitat, including fence marking and habitat improvements, can reach out to AEP wildlife biologists. "There are opportunities for partnerships out there," says Nicholson. "In order for these iconic birds to survive, partnerships between Government, NGOs, and landholders are essential. Working together we can accomplish more and help recover sage-grouse in Alberta."



Photo: ACA, Paul Jones

# Friendlier DESIGNS

## Sites with Low or Seasonal Livestock Use

**Not all situations require a 5-strand barbed wire or a page wire fence.**

Many situations with low or seasonal livestock use can be fenced with a 3-strand smooth wire fence, various types of post and rail fences, or moveable electric fence. Seasonal pastures, cross fences, and horse pastures lend themselves to designs that are much more permeable for wildlife.

### 3-Strand Smooth Wire Fence

Use 3 strands of smooth (barbless) wire. To increase visibility, use coated wire or double-stranded smooth wire – the latter is also more durable than single-strand smooth wire. Note that high-tensile wire should only be used for electrified applications. High-tensile can be difficult for animals to see, horses can sometimes be cut by high-tensile wire, and it is brittle in cold temperatures.

Adjacent to bighorn sheep winter range, this smooth wire fence replaced old 4- and 5-strand barbed wire fence. The fence is 3-strand smooth wire with a 39" (1 m) top wire and 16" (46 cm) bottom wire. Bighorn sheep now readily hop over and duck under the fences.



Photo: Christine Paige

### 3-STRAND SMOOTH WIRE FENCE

- Top wire 40 to 42" (1.02–1.07 m).
- Center wire 28 to 30" (0.71–0.76 m) above the ground; maintain 12" (30 cm) spacing with the top wire.
- Bottom wire 18" (46 cm) above the ground.
- Preferably, no vertical stays.
- Wood or steel posts at 16.5 ft (5 m) intervals.
- To increase visibility, use coated wire or double-stranded smooth wire.

### Braided double-stranded smooth wire



Photo: ACA, Paul Jones

### 3-STRAND SMOOTH WIRE FENCE

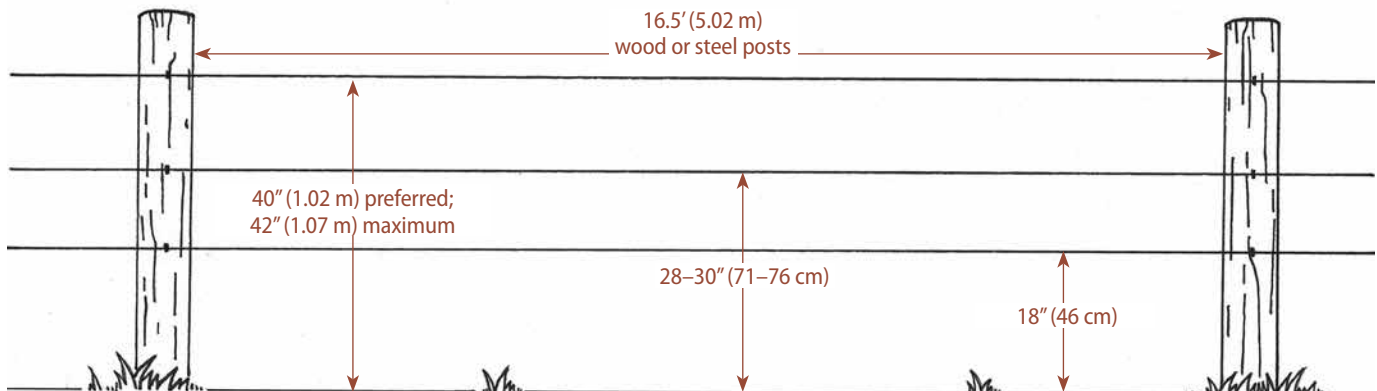

Illustration: Kristen Rumbolt Miller

## Seasonal Electric Wire Fence

**A flexible electric fence that allows passage for elk and other ungulates can still be effective for livestock, particularly horses trained to electric fences.** This two-strand electric fence is useful for keeping livestock out of sensitive habitats or for short duration grazing where year-round fencing isn't desired. The fiberglass posts and wires can be laid down seasonally to allow free wildlife passage.

*To work properly, this fence needs to flex as elk and other animals pass over it. Install as few rigid posts as possible and use the minimum recommended wire tension. Placing the energizer toward the middle of the fence will afford the greatest electrical efficiency.*

### CONSTRUCTION

- Pre-drill 72" x 1" (1.8 m x 2.5 cm) heavy fiberglass posts.
- Drive posts 24" (60 cm) into the ground at a 32 ft (10 m) spacing. A t-post pounder can be used if ground is soft.
- Use treated wooden posts to brace the fence at the ends and center.
- Place a top wire of conductive high-visibility tape, braided wire, or polymer-covered wire no higher than 42" (1.07 m), electrically charged (medium-tensile 12-gauge plastic-coated wire is satisfactory).
- Place a second grounded strand of high-tensile wire at 30" (76 cm).
- Attach strands to fiberglass posts with wire clips that can be removed when fence is laid down.
- Use insulators for attaching hot top wire to wooden posts; grounded wire can be stapled or clipped directly to wooden posts.
- Install a solar electric energizer (size and placement depend on the length of fence).
- Hard wiring is an option if a power source is readily available.



Photo: Jay Kolbe

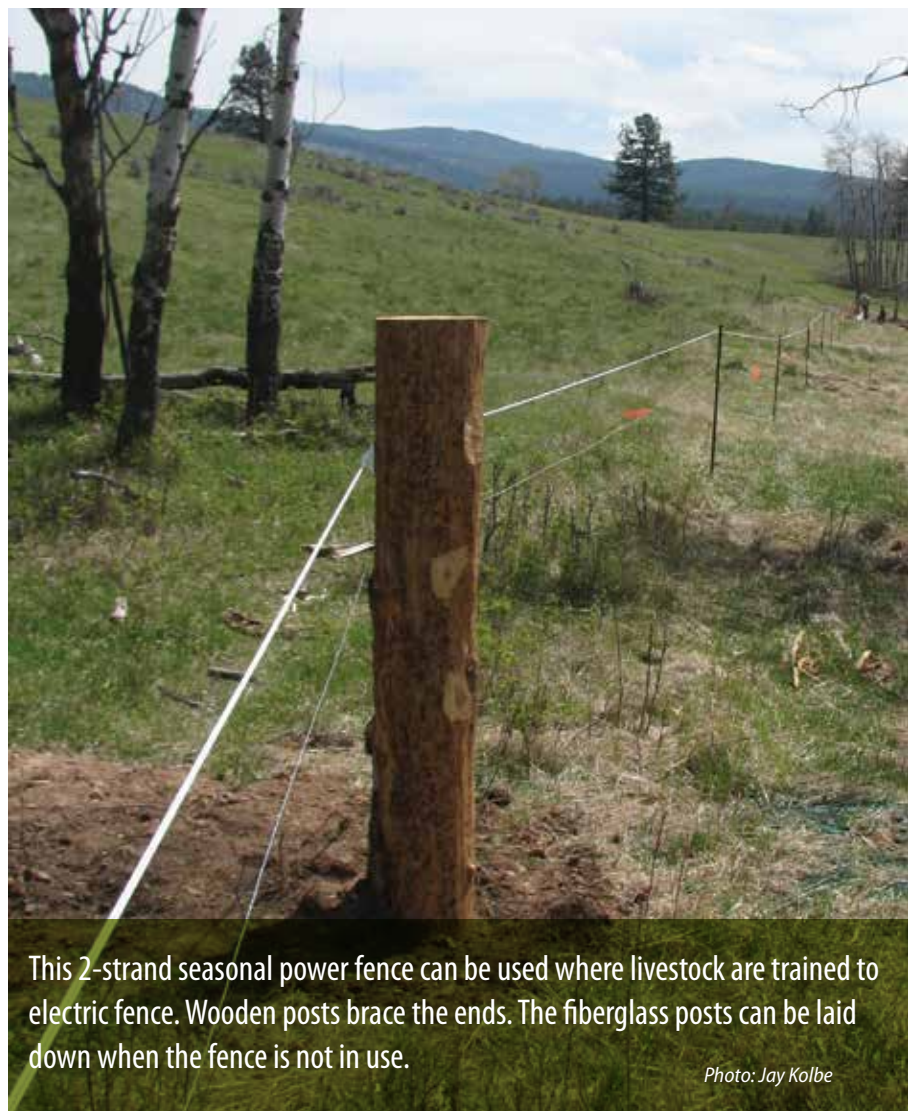

This 2-strand seasonal power fence can be used where livestock are trained to electric fence. Wooden posts brace the ends. The fiberglass posts can be laid down when the fence is not in use.

Photo: Jay Kolbe

# Friendlier DESIGNS

## Moveable Electric Wire Fence

**A moveable electric fence can be used for short-duration grazing, to keep livestock out of sensitive areas such as wetlands, for pasture rotation, and other situations where livestock need to be temporarily controlled.** This fence works well for livestock that have been trained to electric fence.

The design can be tailored to your situation, but a simple fence can be constructed using high visibility tape or “turbo wire” and fiberglass posts or insulated steel posts. A moveable fence can use either a single hot wire (when there is sufficient moisture for an adequate ground) or two wires, the top one hot, the lower wire grounded.

Moveable posts include designs with hooked or pigtail tops for quickly stringing wire, and a tread-in base. These can be rapidly set up and moved as needed. A spooler can be set up on a pickup hitch or trailer for easy deployment. Commercial power trailers that carry 1/2 to 2 miles of fencing and posts, plus solar panels and energizer, as well as electric spoolers are available from Range Ward ([rangeward.ca](http://rangeward.ca)).



Photo: Seth Wilson

### TIPS ON ELECTRIC FENCES

Most electric fence problems are caused by poor grounding. Follow the manufacturer's specifications for grounding the energizer and fence for your fence type and conditions. The number of ground rods needed may vary; a maximum reading of 0.2kv on a voltmeter in dry conditions indicates an adequate ground. Wooden and steel fence posts require insulators for attaching hot wires; ground wires can be stapled or clipped on directly. Fiberglass and plastic line posts do not need insulators but do require special clips for attaching wires. Check the fence regularly to be sure it is charged.



Photo: Brad Downey

### CONSTRUCTION

- Use 40 to 42" (1.02–1.07 m) fiberglass or plastic-insulated steel posts, designed with hooks or loops for wire and tread-in spikes at the base.
- Place one or two strands of high-visibility tape or polymer-covered turbo wire. If using two wires, the top should be hot, the lower wire grounded.
- Top wire should be no higher than 42" (1.02 m); place lower wire no lower than 18" (46 cm).
- Use a solar electric energizer (size and placement depend on the length of fence).



Photo: Christine Paige

A temporary electric fence can be used to keep livestock out of sensitive areas or for pasture management and is easily negotiated by most wildlife.

## Portable Electric Fences Let Ranchers Customize Their Grazing Systems

Norm Ward wants to control time. To do so, he had to get creative with fences.

For many years, Ward owned a cow/calf and steer operation on 8,000 acres in the Porcupine Hills of southwestern Alberta—a rugged region blanketed in native fescue grasslands and dotted with aspen parklands, where Douglas fir, lodgepole, and limber pine crown the hill tops. Ward's goals were to increase the productivity of his operation while also increasing the health of his grass, all in tune with the wildlife and ecosystems of the landscape. It came down to controlling the time livestock had to graze, and the time grass had to recover.

Through years of experience, Ward has become a proponent of regenerative agriculture to restore grassland ecosystems by boosting the diversity of species both above ground and in the soil. Regenerative methods mimic the patterns and pressure of bison herds that once traveled North American prairies, which translates to grazing cattle in high densities for short (sometimes very short) periods and allowing grass long recovery intervals. It also means keeping an eye on the seasons of fast and slow grass growth and the stubble length (the leafy “solar panels” Ward calls them) left behind for grass recovery.

Ward had 40 paddocks fenced with high-tensile electric fence, which worked well for both cattle and wildlife. But he wanted to

increase to 75 paddocks, increase his stock density, and have more flexibility where he laid out fence. “I was fencing ecosystems not just paddocks, following the edges of slopes and habitats, and needed the flexibility to move fence and cattle as needed,” Ward says.

To do so, he used single-wire temporary electric fence so he could move his animals every day to two days and lay out fence in accord with the ranch ecosystems. He also increased his stock density more than fivefold, from 15,000 pounds of animal/acre/day up to 80,000 to 100,000 pounds. The results were evident in the health of the grass, productivity of his cattle, and increase in wildlife of all kinds on the ranch.

To quickly deploy, roll up, and move his temporary fences, Ward built a trailer system that he called the Power Grazer. After many iterations, Ward's current model includes a solar panel for remote use, a deep cycle battery, a reel with a mile of braided turbo rope, and 100 pigtail posts. With an extra reel and posts, the Power Grazer can carry and power two miles of fence. The trailer can be easily towed with a pickup or quad, allowing quick deployment. “It takes one person an hour to put up or take down a mile of fence,” says Ward.

The 1/4” rope is reflective and has two copper wires braided in for conductivity. It is easily seen by wildlife and will withstand 1,300 pounds of force before breaking. Deer, elk and other ungulates can easily pass over or under, and raptors can't perch on the rope or pigtail posts.

The ease of use and success of his trailer system lead Ward to create a new business, Range Ward ([rangeward.ca](http://rangeward.ca)), to market the Power Grazer and Razer Grazer, a smaller trailer that carries 1/2 mile of fence.

The Power Grazer and Razer Grazer are particularly useful in large landscapes, remote areas, and rugged terrain. The trailers allow flexibility in deploying fence for a wide range of uses, from managing cattle grazing time and grass rest periods, to fencing out animals from sensitive habitats or reclamation sites. Ward found he could replace permanent fence with temporary electric fence to better adjust how he managed the landscape with an eye to restoring its abundance and diversity.

Agriculturalists across Alberta, the prairie provinces, and in the States have adopted the Power Grazer and Razer Grazer to manage their cattle and grass. Many find that changing their fence, and controlling time, can transform their production and stewardship of the land.

See the Range Ward website, [rangeward.ca](http://rangeward.ca), for product information on the Power Grazer and Razer Grazer.

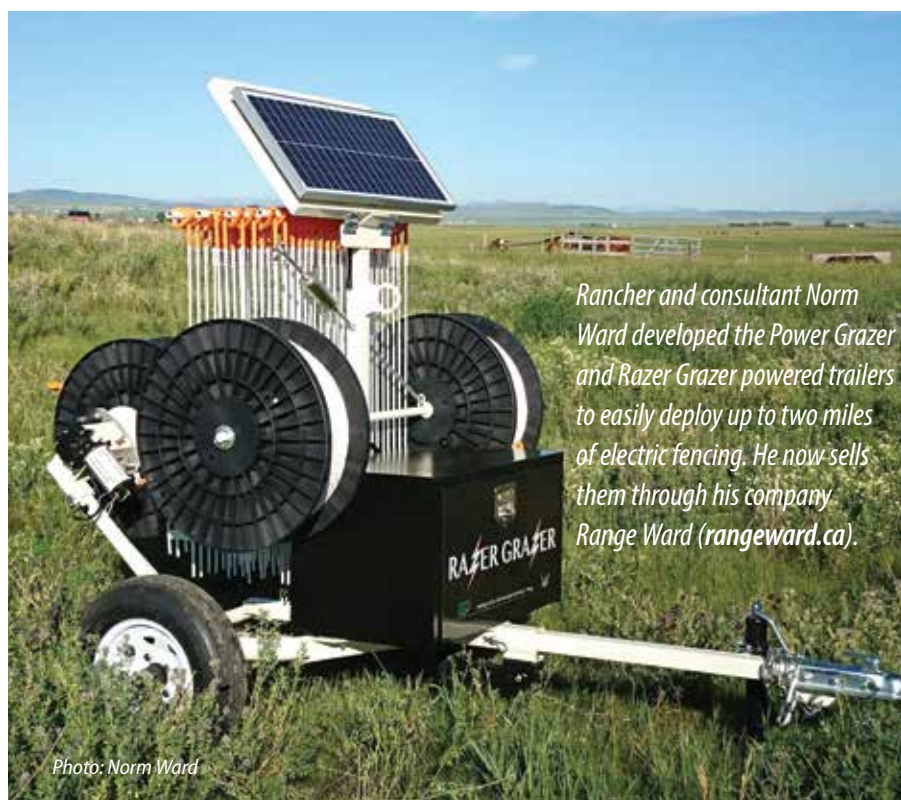

*Rancher and consultant Norm Ward developed the Power Grazer and Razer Grazer powered trailers to easily deploy up to two miles of electric fencing. He now sells them through his company Range Ward ([rangeward.ca](http://rangeward.ca)).*

Photo: Norm Ward

# Friendlier DESIGNS

## Post and Rail Fence

A post and rail fence is highly visible to wildlife and can be constructed for situations with or without livestock. Rail fences can either use a top rail with wires below, or two to three rails total. For wildlife, a 2-rail fence is preferable.

Unless the fence is quite low, use rounded poles for the top rail, rather than a square or split rail, to prevent too much snow build-up in winter, which can deter elk and deer. Also, unless the fence is easily jumped and there is ample clearance underneath, boards or planks are not recommended as these can create a visual barrier.

Illustrations: Kristen Rumbolt Miller

### CONSTRUCTION

- Use pressure-treated 6 to 8 ft (1.8–2.4 m) posts, spaced 10 to 14 ft (3–4.3 m) apart.
- Use pressure-treated poles for top rail—a half-round rail will attach more snugly and require shorter bolts. Place the top of the rail at 40" (1.02 m) and maximum 42" (1.07 m) above the ground.
- Place smooth lower wires at 18" and 28" (46 cm and 71 cm) above the ground. The top wire should be at least 12" (30 cm) below top rail.
- OR place pressure-treated poles for lower rails, the bottom rail placed with at least 18" (46 cm) clearance from the ground.

### POST AND RAIL FENCE

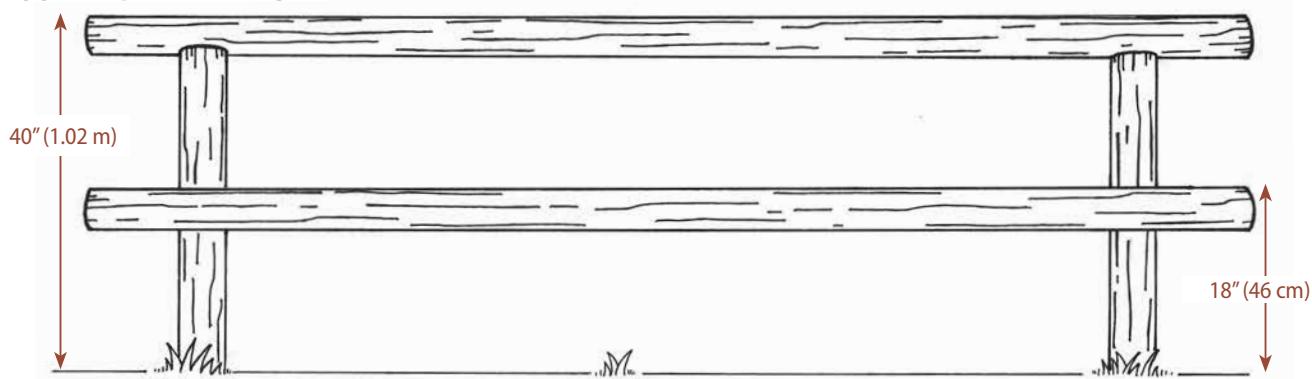

### POST AND 2-WIRE FENCE

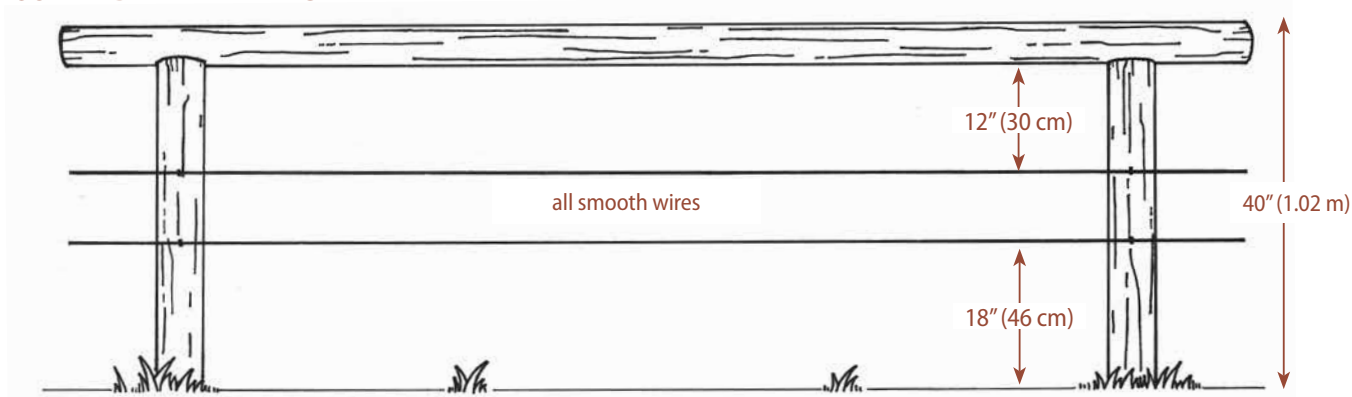

### POST AND RAIL WITH 3 SMOOTH WIRES

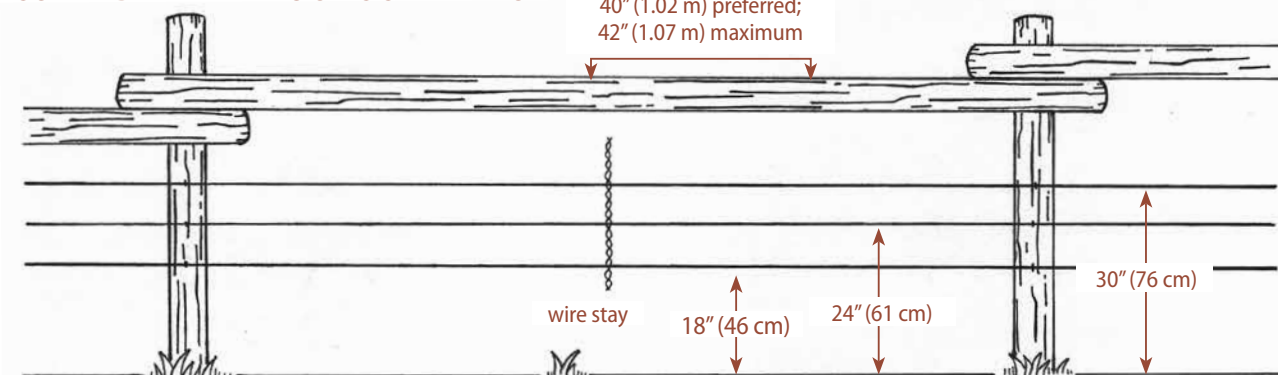



## Horse Pastures

**A wide variety of fences can be used to contain horses, including post and rail, pipe, smooth wire, vinyl or electric poly-rope fence.** Consider safety when choosing a fence. Horses have difficulty seeing wire fences, and if spooked can tangle in wires or suffer injuries on barbs and smooth high-tensile wire. Post and rail, pipe, vinyl and electric poly-rope fences are much more visible to both horses and wildlife and reduce the risk of injury. Wood fences should be constructed with bolts and treated rails and posts. Nails can become a hazard as a fence wears and horses can break worn boards and weak rails.

If electric fence is an option, a 2-strand electric braided poly-rope fence is highly visible and allows animals to bounce off of the fence without injury to themselves or the fence. Nearly any standard fence can also be electrified with a single wire to prevent horses from touching or leaning over the fence—use electric braid or tape for visibility. Temporary pastures can be enclosed with a single strand of electric tape or braid.

The usual wildlife friendly standards apply. Keep the top of the fence no higher than 42" (1.07 m), which is adequate to contain nearly all horse breeds in most pasture situations (jumpers are an exception). Allow 12" (30 cm) clearance between the top and second rails or wires. Allow a clearance of at least 18" (46 cm) between the ground and the bottom rail, wire, or pipe for wildlife to scoot underneath.



Rail fences are safer for both horses and wildlife—a top rail combined with smooth wire will contain most horses. Adding a wire stay will keep wires in place.

Photo: Christine Paige

## Sites with High or Continuous Livestock Use

**Most livestock pastures do not require a 5- to 6-strand barbed wire fence.** In many situations, a 3- or 4-strand barbed wire fence, a combination of smooth and barbed wire, or an electrified fence will work well for livestock control, particularly if the pasture quality inside the fence is as good or better as outside.

*Create seasonal openings by leaving a gate open, lowering rails or wires, or using sections of lay-down fence during months when livestock are not present.*



Photo: Christine Paige

### TIPS FOR LIVESTOCK FENCES

Sheep, bison, and cows with calves may require a more impermeable fence for control. If you must use fences with page wire or more than four wires, follow these tips:

- Consider the placement of the fence perimeter carefully and limit the extent of impermeable fence wherever possible.
- Avoid excluding wildlife from streamsides and water sources or cutting off migration and travel corridors.
- Keep the fence height to a maximum of 40 to 42" (1.02 to 1.07 m) and create periodic crawl-openings for fawns and calves by raising the bottom 18" (46 cm) from the ground, placed where animals typically travel.
- Avoid topping page wire fences with barbed wire. In any situation, allow 12" (30 cm) between the top wire and the next wire below – whether barbed or page wire.
- Create seasonal openings using lay-down fence sections or gates to open the fence during months when livestock are not present.



Photo: ACA, Lee Moltzahn

# Friendlier DESIGNS

## 4-Strand Barbed Wire for Cattle or Sheep

**Page wire fence, the most commonly used type of fence on sheep range, is also the most problematic for wildlife.** It can block wildlife passage, particularly for fawns, calves, pronghorn, and medium-sized animals that are unable to jump fences. When combined with barbed wire, it has the highest rate of entanglements for wildlife.

An alternative for sheep and cattle range is a 4-strand barbed wire fence that controls livestock but still allows for passage of pronghorn, deer, moose, and elk.

**For cattle,** use a wire spacing of 18–22–28–40/42" (46 cm–56 cm–71 cm–1.02/1.07 m). The top wire should be at 40 to 42" (1.02 to 1.07 m) or less. Allow 12" (30 cm) between the top two wires and 18" (46 cm) between the bottom wire and the ground. Use a smooth bottom wire.

**Sheep** require a low fence that would block most wildlife from crawling beneath the fence, however a 4-strand fence for sheep can have a maximum height of 32" (1.81 m) high, which is low enough for most wildlife to jump. Allow at least 10" (25 cm) between the top two wires. As a lower fence is easier for deer and elk to jump, this smaller spacing between top and second wires will usually be adequate. The bottom wire should be smooth wire and at least 10" (25 cm) above the ground.

### SHEEP AND CATTLE 4-STRAND BARBED WIRE FENCE

(Adapted from Wyoming Game and Fish Dept., 2004)

Recommended Wire Heights Above the Ground			
	Cattle	Sheep	Sheep & Cattle
Top wire - barbed	40–42" (1.02–1.07 m)	32" (81 cm)	38" (97 cm)
2nd wire - barbed	28" (71 cm)	22" (56 cm)	26" (66 cm)
3rd wire - barbed	22" (56 cm)	16" (41 cm)	18" (46 cm)
4th wire - smooth	18" (46 cm)	10" (25 cm)	10" (25 cm) minimum

*A bottom smooth wire aids passage for pronghorn, deer, and other wildlife.*

## Combination Smooth and Barbed Wire Fence

**In many situations, a combination of smooth wire and barbed wire can effectively contain livestock and allow for easier wildlife passage.** Smooth wire can be used for the top and bottom wires and one to two barbed wire strands are used for the center strands. Double-stranded wire or coated wire will increase visibility for wildlife. The top wire should be 40 to 42" (1.02 to 1.07 m) high or lower, and the bottom wire at least 18" (46 cm) above the ground to provide wildlife clearance. Allow at least 12" (30 cm) between the top and second wires.

### CONSTRUCTION

- Place top smooth wire at 40 to 42" (1.02–1.07 m) maximum height. Double-stranded smooth wire or coated wire is recommended.
- Allow at least 12" (30 cm) between top and second wires.
- Place bottom smooth wire at least 18" (46 cm) from the ground.
- Use barbed wire for center two wires.



Photo: Christine Paige

## 4-STRAND BARBED WIRE WITH BOTTOM SMOOTH WIRE

Illustration: Kristen Rumbolt Miller

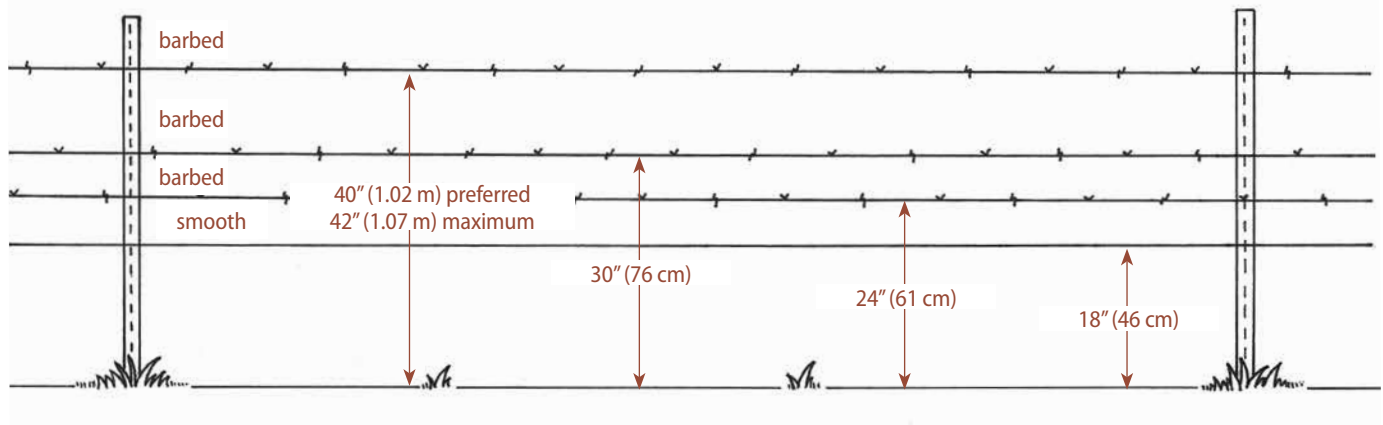

## Wire Suspension Fence

**Suspension fences have been used successfully on ranches for decades, and with modern materials they are proving to be durable, long-lasting, and low maintenance.**

Wires are suspended across a long run between anchor posts, with fence stays placed at regular intervals to keep the wires from tangling. The fence is flexible and resilient when struck by large animals, allowing elk, deer, and moose to pass over easily, yet immediately returns to shape and contains livestock effectively.

A wildlife friendly suspension fence uses no more than four wire strands. Anchor posts are spaced at least 50 ft (15 m) apart, up to a maximum of 100 ft (30 m) apart, or much closer in uneven terrain. Adequate bracing is essential to maintain wire tension. Posts may be treated wood, metal, or one of the commercially available bracing systems (for an example, see Southwest Fence Systems braces at [www.swfence.com](http://www.swfence.com)).

To maintain wire spacing, lightweight wood, fiberglass, or composite stays are evenly spaced between the posts. Be sure stays hang free of the ground and won't catch on vegetation and twist the fence as animals pass over. The stays also reduce tangling and improve visibility for wildlife and livestock. Twisted wire stays are not recommended, as they are easily bent by wildlife passing over the fence, increasing fence maintenance and the risk of entanglement.

Place the top wire no higher than 40 to 42" (1.02–1.07 m) and the bottom wire at 18" (46 cm). Maintain 12" (30 cm) between the top two wires. A variety of barbed and smooth wire combinations can be used, depending on the situation. For example, use a bottom smooth wire where pronghorn or young deer, elk, or moose are present. A top smooth wire will aid passage for adult deer, elk, or moose. Use smooth wire for both bottom and top wires in areas with both pronghorn and elk, or both adult and young animals.

Suspension fence has the advantages of using far fewer posts than conventional fence – a savings in materials and labor, and a benefit where posts are difficult to drive. It also reduces or nearly eliminates long-term maintenance.

### CONSTRUCTION

- Place anchor posts 50 to 100 ft (15–30 m) apart; closer in uneven terrain.
- Use sufficient bracing to maintain wire tension.
- Use a maximum of 4 wires: top wire no higher than 40 to 42" (1.02–1.07 m), 12" (30 cm) between the top two wires, and bottom wire at a minimum of 18" (46 cm).
- Evenly space lightweight fence stays (wood, fiberglass, or composite) between the anchor posts. Wire stays are not recommended because they easily get bent over.
- Use smooth wire on top and bottom to ease wildlife passage.
- Suspension fence should be periodically checked for twisting, especially during peak migration/movement periods.

A suspension fence has unanchored stays with posts set far apart, allowing the fence to flex as wildlife passes over or under. Lightweight fiberglass, wood, or composite poles can be used as stays, and the top and bottom wires should be smooth wire.

## WIRE SUSPENSION FENCE

Illustration: Kristen Rumbolt Miller

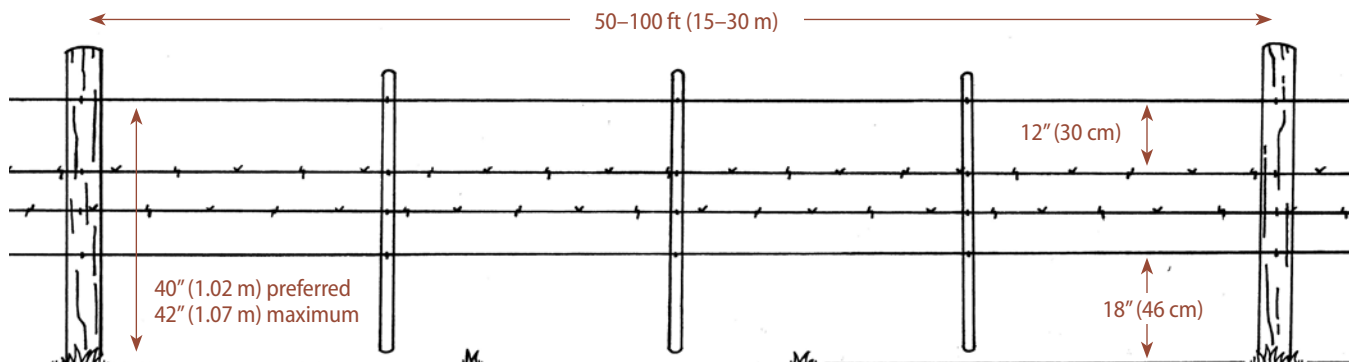

The Tomahawk Ranch in Parkland County encompasses 14,500 acres, including grassland, woodland, and a 4,000-acre old lakebed that was turned to pasture years ago. When Gerry Taillieu and his family took over management of the ranch in 2001, the ground was overgrazed and in poor shape.



## Tomahawk Ranch Invests in Friendlier Fences for Healthy Grass, Stock, and Wildlife

Over many years, through smart management of grazing, rest, and water, the Taillieu family restored the grass and increased cattle production on the Tomahawk Ranch. In 2013, they were awarded the Alberta Beef Producer's Environmental Stewardship Award for their dramatic improvement of the ranch. Re-thinking and improving the fences has been integral to Taillieu's approach.

Tomahawk is a combined cow-calf and yearling operation—in 2019, running 2,300 cows and 1,000 yearlings. Taillieu uses a rest and rotation system adapted to the landscape, with higher stock densities and longer rest periods. The old lakebed produces so much forage now that they graze through the winter.

"The combination of yearlings with the cow-calf operation is ideal for us," says Taillieu. "Early in the season we can't move cows with calves very often, but the yearlings we can move faster."

As the grass returned so did wildlife, and the ranch now hosts abundant elk, moose, white-tailed deer, and mule deer; all of which can affect fences. Many of the original fences were badly damaged, so the ranch has set about steadily repairing and modifying all the fences to be both friendly to wildlife and practical for the operation.

Year by year, Tomahawk Ranch is altering the perimeter fences by changing out traditional barbed wire for a 5-strand fence with smooth wire on top and bottom and three strands of barbed wire between. The top wire is set at 42" height and the bottom strand at 18" above the ground, which wildlife can easily jump over or slip under.

The result is dramatically less maintenance, saving time and money. "Our old fences take a beating, but the new fences hardly have any damage," reports Taillieu. "Last year we regularly had 30 to 60 elk jumping the fences, but on the new wildlife friendly fence we only had to replace two to three staples this spring."

Neither does the 18" bottom wire create a problem with straying calves. "We had 1,300 calves in a pasture up against one of our perimeter fences, and in four weeks

only one calf got out," Taillieu says. "With the 18" bottom wire it went right back in again. Our old fences created a lot more trouble with calves getting out and not being able to get back in."

Tomahawk Ranch is also changing over the network of interior cross fences to permanent 2-strand electric fence built with standard smooth wire, with a top hot wire and bottom grounded wire. The operation uses some portable electric fence as well.

"We want to hold the cattle where we want them," says Taillieu. "Electric fence is half to a third the cost of barbed wire, and once they're trained to it, cattle don't want to reach through. But game can get through easily, and we've had almost no issues." Further, with regular pasture rotations the cattle are always on abundant forage, and less likely to push and damage a fence.

To help fund the new fences, the family sought out partnerships with Canadian Agricultural Partnership (CAP) and ALUS Canada, which helps operations improve marginal farmland for production, wildlife, and ecosystem health.

Taillieu recommends such partnerships, and also offers some planning advice: "If you do any water development, be sure to design your fence around what you've done with water."

In 2017, Tomahawk Ranch was purchased by Western Ranchlands, a group of land managers committed to profitable ranching dovetailed with conservation. Western Ranchlands and the Taillieu family continue to manage the landscape to produce healthy grasslands and healthy livestock in concert with nature and wildlife.

"We're a progressive traditional ranch," says Taillieu. "All our work is done on horseback, but we try to learn as much as we can about what's new. We're not a showplace—we're motivated to make money—but this is a win-win for the ranch and wildlife. We're getting more elk, deer, and moose because of the operation. I'm really excited about the new fences—they'll make a big difference."



# Friendlier DESIGNS

## 3-Wire High-Tensile Electric Fence

Researchers in Wyoming found that a flexible 3-wire high-tensile fence with a hot – ground – hot configuration is not only effective for containing cattle and bison, but allows elk, mule deer, and pronghorn to traverse the fence. They found that wild ungulates were not usually deterred by electric fences even with charges ranging from 0.5 and 4.5 joules, perhaps because of the insulating properties of their hair. Although wild ungulates were occasionally shocked when they nosed or bit a wire, or touched hot and grounded wires together, most animals readily negotiated the fences.

Further, the researchers determined that 3-wire fences effectively contained bulls separated from cows coming into estrus, and calves from cows in the fall. They also found that a 3-wire fence was just as effective for containing bison as a 4-wire fence. A 2-wire fence can be used for areas without weaning calves but, curiously, pronghorn showed a high aversion to 2-wire fences, perhaps because of the novel height and their general reluctance to jump fences rather than crawl under (Karhu and Anderson 2003, 2006).

High-tensile fences require proper construction techniques, including adequate braces, proper tensioning, care not to kink or break wire, and proper attachments and insulators for line posts and braces. The flexibility of the fence is key to allowing wildlife to pass over and through the fence. Fiberglass posts are used for all line posts, and wooden posts are used only for braces, direction changes and gates.

High-tensile fences need minimal maintenance, provide great strength, can be easily electrified and will outlast most other fences.

Note that smooth high-tensile wire can be difficult for animals to see and is not recommended for horses. Adding markers or flagging to the top wire can help. Keeping the fence powered prevents wildlife from leaning into it. If power is off, consider laying the fence flat to the ground if it will not create an entanglement hazard.



Photo: Rory Karhu

A 3-wire high-tensile electric fence is effective even for separating bulls from cows in estrus, and for containing bison. Using the proper tension is key to prevent wildlife damage.

## 3 WIRE HIGH TENSILE ELECTRIC FENCE

Illustration: Kristen Rumbolt Miller

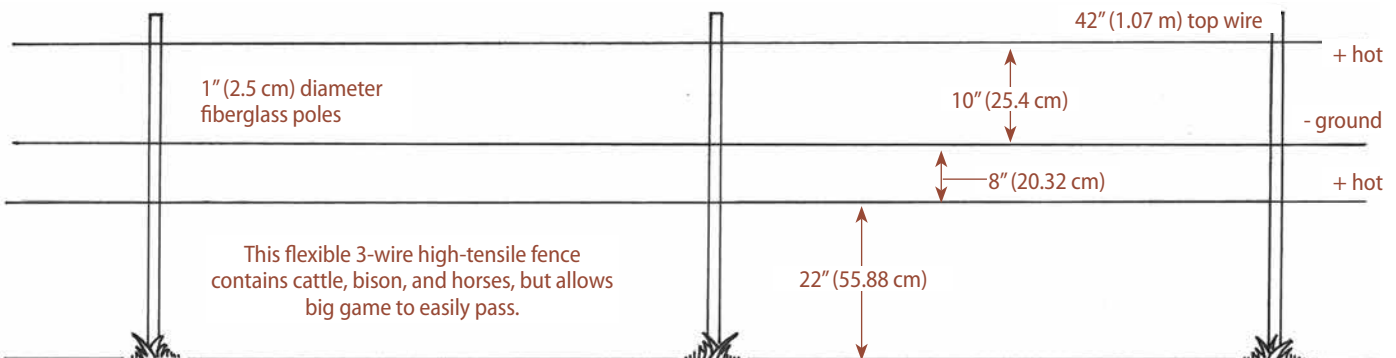



Photo: Rory Karhu

### 3-WIRE HIGH-TENSILE ELECTRIC FENCE CONSTRUCTION

Maintaining fence flexibility is key to allowing wildlife to traverse the fence.

- Use fiberglass line posts no greater than 1" (2.5 cm) in diameter.
- Brace fence with wood posts at least 5" (13 cm) in diameter. Brace all corners, gates, and direction changes greater than 15 degrees. Appropriate insulators are needed with wooden posts.
- Space line posts 45 to 60 ft (14–18 m) apart. Do not use fence stays—stays make it harder for wildlife to pass between the wires and may cause the fence to flip.
- Smooth, 12.5-gauge, Class III galvanized wire with a tensile strength of 170,000 PSI and breaking strength of 1308 lbs. is adequate.
- Increase visibility by using flagging, fence markers or high-tensile wire coated for visibility.
- Top wire is hot; second wire is grounded; bottom wire is hot.
- Space wires at 22–30–40/42" (56 cm–76 cm–1.02/1.07 m) from the ground. The top wire should be no higher than 42" (1.07 m) with 10" (25 cm) between the top two wires. The 10" (25 cm) spacing is necessary for cattle to contact both hot and ground wires but poses little hazard for wildlife due to the fence's flexibility. A bottom wire placed at 22" (56 cm) allows both young and adult wild animals to pass under easily.
- Connect wires to posts with metal clips or fasteners designed for electric fences; use porcelain insulators on wooden braces.
- Tighten wires to 150 lbs. tension. If too tight, the wires are more likely to break. Although high-tensile wire has a high breaking point, it is also more brittle, and easily broken if tightly bent or kinked.
- Place solar energizer according to manufacturer recommendations.
- Ground fence properly according to the energizer instructions and add extra rods as needed. Locate ground rods at fence ends and intermittently in between.
- Ground rods are relatively cheap and extra rods will ensure the fence will be effective.
- When livestock aren't present, either drop the wires flat to the ground or keep the fence electrified to prevent wildlife damage. (Keeping the fence powered can also prevent the battery from freezing and prolong battery life).
- Securely attach electric fence warning signs intermittently along the fence and at crossing points.

# Friendlier DESIGNS

## Bison Fence

**In Alberta, bison are classified as livestock throughout most of the province and may be grazed on agricultural dispositions on public lands (with special permission) or on deeded lands.**

Fence security for bison and fence permeability for wildlife are both important considerations when grazing bison. Sound husbandry practices that provide bison with healthy range, water access, and space to move, while allowing effective grassland rest periods also factor into fence design and placement. Content bison are less likely to push or test fences.

A bison perimeter fence can be constructed with five smooth, taut wires. Place the bottom wire at 18 to 20" (46–51 cm) and the top wire at 60" (1.5 m). Allow 12" (30 cm) between the bottom wire and second wire from the bottom. Place the top three wires at 10" (25 cm) intervals. Install spring tensioners on the top, bottom, and second to bottom wires to allow the wires to give if wildlife push through or attempt to jump over. Build in fence clips so wires can be lowered when bison aren't present.

Electrifying the third (middle) wire adds security for bison. Another option is to add an electrified wire strung on outrigger insulators attached to every third post. As detailed in the previous section,

electrified high-tensile smooth wire can adequately contain bison in internal pastures. Use an energizer adequate for the length of the fence and check the voltage regularly.

Bison must be trained to electric fence in a secure pasture for one to two weeks before being moved to larger pastures. Bison calves can be conditioned during weaning.

For a fence 60" (1.5 m) or higher, provide wildlife crossing structures at 1/4-mile intervals, at known crossings, along movement corridors, and near water. Building in jump rails or pulling the top two and/or bottom two wires together with quick clips can allow easier wildlife passage. For a wildlife jump rail in bison fence, place the top rail at 54 to 56" (1.37– 1.42 m), bottom rail at 18" to 20" and allow at least 12" between the bottom and center rail. Bison can easily clear anything lower, but most adult elk and moose can clear the top rail, and younger animals can crawl under or through.

More detailed information and considerations for bison fence can be found in *Fencing Guidelines for Bison on Alberta Public Lands* (Gates 2006).

A 5-wire fence for bison with smooth wire and spring tensioners to ease wildlife passage.



Wildlife crossings can be created simply by clipping wires together.

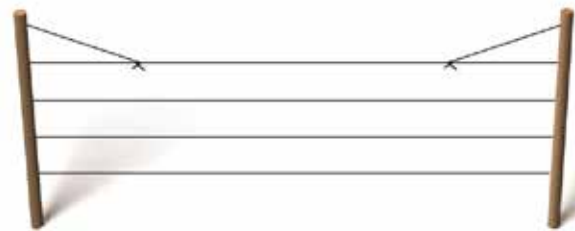

Permanent Jump rails for big game in bison fence

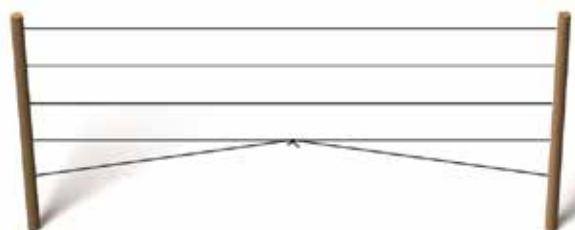
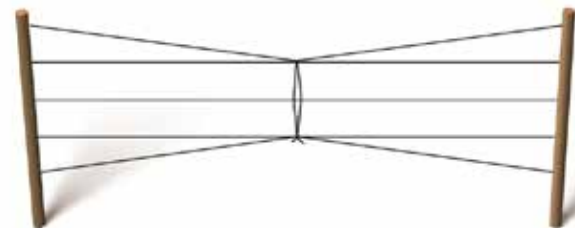
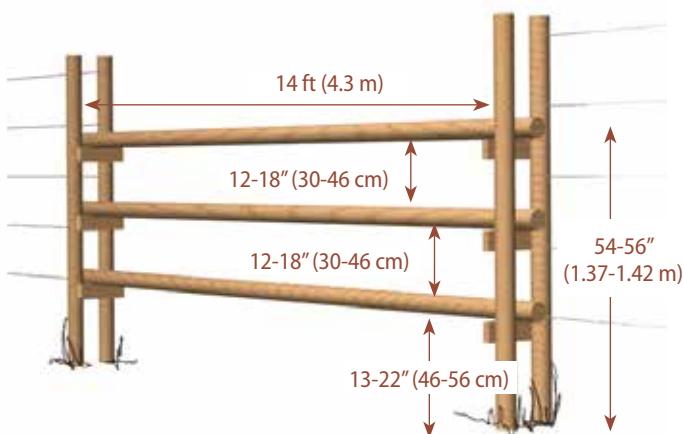
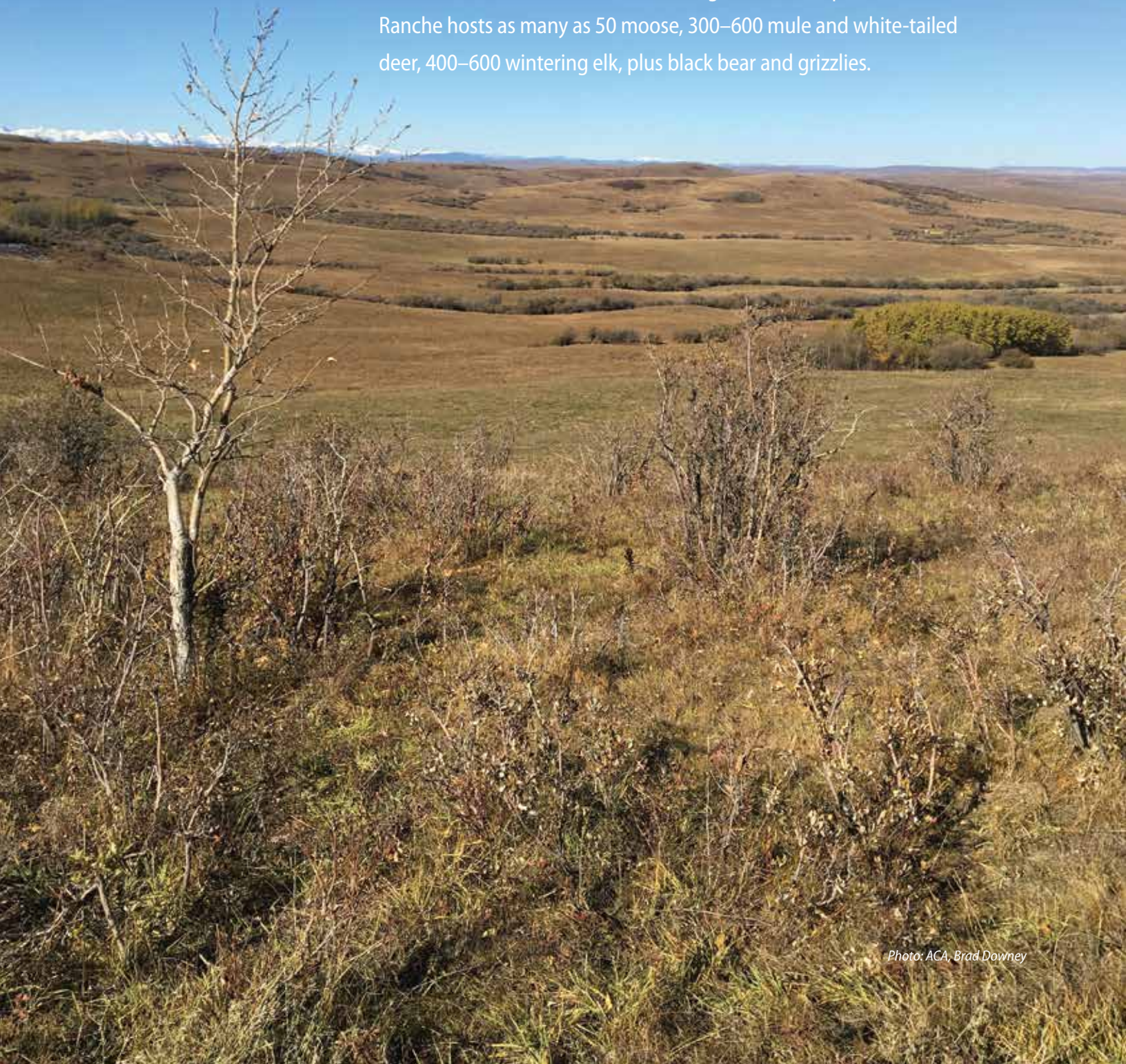





*Photo: Christine Paige*

In 1886, A.E. Cross established the A7 Ranche in the Porcupine Hills along the Rocky Mountain Front near Nanton. It is the oldest ranch in Alberta still owned and operated by the same family. Today, the third and fourth generations of the Cross family carry on a deep tradition of stewardship that focuses on maintaining healthy grasslands that produce healthy cattle and abundant wildlife. Encompassing about 13,000 acres (5,260 ha) of wildlife-rich grassland and parkland, the A7 Ranche hosts as many as 50 moose, 300–600 mule and white-tailed deer, 400–600 wintering elk, plus black bear and grizzlies.



## Tradition and Innovation on the A7 Rancho

On the A7 Rancho, the Cross family runs a cow/calf operation with about 2500 head and grazes their herds to mimic the ancient patterns of bison movement that most benefit the grass. “We graze for the maximum health of the plant,” states John Cross, owner of the A7. “There’s no specific recipe: we focus on the goal.” The Crosses adapt their stock densities, grazing periods, and rest periods to the seasonal and yearly patterns of abundance and scarcity in the landscape.

With 120 permanent fields, the ranch has a lot of fencing, and traditional 5-strand barbed wire fence would be prohibitively expensive. Instead the family has shifted to electric fences that are more economical, keep their herds where they want them, and allow wildlife easier passage.

The Crosses began by using permanent 2-strand electric fence but found that the grass grew up over the lower wire, shorting out the fence. Instead, they have shifted to permanent 1-strand electric fence, using a single high-tensile wire at 32” height and wide spacing between fence posts.

“Buy the best product—it will save money in the long-run,” advises Cross. “Use high-tensile wire with a minimum of 200,000 psi breaking strength if you have a lot of wildlife. How you power your fence is essential: buy the best energizer you can afford that can



Photo: ACA, Paul Jones

deliver a minimum of 5,000 volts. If possible, use a direct plug-in and a remote control to turn things on and off if you have problems.” The ranch also powers fences year-round so wildlife will get trained to and respect the fence.

Flexible posts are often used with high-tensile electric fence, are relatively easy to install, and have some give that allow wildlife to pass over the fence easily. However, Cross found that flexible posts can break in the cold and are only good to about -15° C (5° F)—simply not tough enough for ranching in Alberta.

“We’ve gone to 3-inch wood posts—it’s the best solution we’ve come up with,” says Cross. Their spacing depends on the topography: in the rolling terrain of the A7, post spacing can vary from 10’ to 60’ (3–18 m). While wire tension is important, high-tensile doesn’t mean maximum tension. Cross recommends pulling the wire very tight during construction, but then backing off to just where the wire maintains the right height.

As for gates, on the A7 they simply use a single hot braided rope with an insulated handle. In the Crosses experience, wildlife destroyed their barbed wire gates. Typically, wildlife don’t cross at the rope gate, but if they do hit it, the hook on the plastic handle will straighten and can be readily repaired.

“Plan your water first,” Cross advises, who says he learned the hard way. The A7 uses an extensive system of 25 miles of 3” water line and 70 water tanks. “Before you build any permanent fence, get a long-term water plan developed first, and make a plan that gets your water system away from the riparian.”

Everything on the A7 is done for long-term land stewardship, high-quality production, and practicality. The cattle are grazed on grass, which keeps herds healthy and content. By grazing fewer, larger herds, the ranch can decrease grazing periods and labor. Electric fencing is used to save money, maintenance, and time. Cattle are moved by cowboys on horseback using low-stress handling techniques that keep the cows and calves relaxed. Attention to the health of the land allows the A7 to market hormone-free beef.

“Our family stories are written on this land, and our children’s future is here, too,” the Cross family states on the A7 Rancho website. “This makes us think long-term about the land and water health, and a sustainable economy. As landholders, we honor the land stewardship responsibilities that come with the territory, and we are proud of our well-known commitment to environmental conservation. For us, it is about respecting a harmonious land/people relationship that has stood the test of time for 134 years.”



Photo: ACA, Paul Jones

# Friendlier DESIGNS

## Openings, Crossings and Passes

**Fence passes reduce injuries, keep fawns and calves from being stranded, provide openings for animals unable to jump fences, and help wildlife cross in deep snow.**

Wildlife crossings and openings can reduce fence damage and decrease maintenance costs.

You can include wildlife crossings in any fence design. Short sections can be altered to wildlife friendly standards to help wildlife cross, or gates and jumps can be added. The simplest solution is to install gates that can be secured open when the pasture isn't used by livestock.

Animals are creatures of habit—place jumps and openings where there are signs of habitual crossing by wildlife. Look for worn trails, tracks, hair caught on fence wires, and any place fence is regularly damaged. Also place crossings in fence corners and sites where animals are funneled by topography or the fence line.

Fence openings and passes are especially important when fawns and calves are small (June 1 through summer), for seasonal wildlife movements and ranges, and when snow accumulates, making permeable fences impermeable.

*An easy solution is to secure gates open in seasons when livestock aren't present.*

### FENCE ALTERATIONS CAN INCLUDE:

- Lowering the top wire or rail to 42" (1.02 m) or less.
- Increasing the distance between top and second wires to 12" (30 cm).
- Raising the bottom wire or rail to 18" (46 cm) or more.
- Replacing the bottom and top wires with smooth wire.
- Increasing visibility with a top rail, PVC pipe, high-visibility tape or braid.

### WILDLIFE OPENINGS AND PASSES CAN INCLUDE:

- Gates secured open.
- Dropped rails and wildlife jumps.
- Sections with adjustable wires or rails.
- Sections of seasonal lay-down fence.
- PVC modifications for big game passage.

Use your local topography and patterns of wildlife travel to help you determine the best placement for crossings. Look for signs of wildlife use and travel such as game trails, tufts of hair caught on fence wires, trails to water, or gullies and swales that act as wildlife corridors.



*Photos: Christine Paige*





*Photo: Christine Paige*



*Photo: ACA*

In the wide-open prairie and hoodoo country along the Milk River in southern Alberta, Deer Creek Ranch runs a cow/calf operation that benefits wildlife while producing top-quality Certified Angus Beef. The area is remote, without power or cell coverage, and is still a stronghold of native shortgrass prairie—home to at least 103 wildlife species, from ferruginous hawks and sharp-tailed grouse, to pronghorn, moose, mule deer, and elk.



## Deer Creek Ranch Dovetails Sustainable Beef Production with Conservation

Since 1939, the 47,000-acre (19,000 ha) Deer Creek Ranch was in the hands of the Gilcrest family, who began working with the MULTISAR program to improve range management and wildlife habitat. In 2011, a group of four shareholders, all in the cattle business, purchased the ranch. Deer Creek Livestock Company has continued and expanded the ranch's involvement with MULTISAR to dovetail conservation with efficient and high-quality cattle production. Wildlife friendlier fences and fence modifications are a big part of Deer Creek's approach.

"We're trying to be as environmentally friendly as we can," explains Jeff Smith, one of the partners. "We started with the MULTISAR assessments of range management, soils, grass, and wildlife, which were a huge help to focus our efforts."

The operation runs 1,200 cows, all black Angus, that are kept in age groups to graze and feed separately. Multiple pastures, from 80 to 5000 acres (12–2,000 ha), allow flexibility to move the animals through the seasons and according to nutrition. "We move the cows and calves through pastures as the grass can take it; the younger cows, younger bulls, and mature bulls also all have different feeding requirements," explains Smith.

With over 100 miles of perimeter and pasture fences, there's a lot of fence to maintain. To date, Deer Creek Ranch has altered 50 to 60% of their fences to wildlife friendly specifications by installing 4-wire fences with three barbed strands plus a barbless smooth wire at the bottom set at 18" above the ground, and the top wire no higher than 42". In addition, in sagebrush habitats, they have placed reflective markers on the wires to make the fences more visible for sharp-tailed grouse.

"The 18" smooth wire benefits pronghorn—they go under easily without injury—and it doesn't affect our cattle management at all. Young heifers haven't learned to respect the fence yet, so in areas of pressure we run 5 wires or an electric fence," reports Smith. "Wildlife damage to our fences has been decreasing as we better understand the movement of wildlife and modify our fences accordingly."

In this dry prairie country, producing top-quality cattle requires smart management of grass and water. The ranch runs along both sides of the Milk River for 12.5 miles, including riparian bottomlands essential to wildlife, and rises 1000 feet (305 m) from the river to hilltops. "We've tried to minimize our footprint on the riparian and the river by using appropriate fencing, solar to pump water away from the river, and solar-powered water tanks and drinkers," says Smith. Deer Creek also produces hay, alfalfa, and sorghum—some flood-irrigated and some pivot-irrigated—for their own seasonal feeds and to sell to neighbors. A 10'-high exclusion fence protects their stackyard from deer and elk.

In addition to the permanent wildlife friendlier fences, Deer Creek Ranch uses three portable solar electric fences to manage their pastures. Each of these is a two-mile, single-strand fence run off a Power Grazer trailer produced by Range Ward (<https://rangeward.ca/>). The trailer includes a solar-charged energizer, an electric reel for two miles of braided rope, and storage for the pigtail posts.

The portable fence allows flexible management of the grass and wildlife can

easily see and negotiate the single braided electric rope. Although an investment, Smith is enthusiastic about what they can accomplish with the portable electric fence system. "It saves money over time and is worth every penny," he reports.

Deer Creek Livestock Co. received the Alberta Beef Producers (ABP) 2020 Environmental Stewardship Award. Each year, ABP recognizes a cattle operation that demonstrates leadership in environmental stewardship—one that contributes to the land while improving productivity and profitability. "We are happy and honored and a little overwhelmed on receiving it," says Smith. "It's given us the assurance that we're on the right track and gives customers and clients the knowledge that there are good beef producers out there."

"Changes are scary," Smith continues. "They're a long-term investment and it takes five to ten years to know you're on the right track. We want to be stewards of the land, to leave the land in better condition and for the next generations."



Photos: Ramblin' Rose Creative, [ramblinrosecreative.com](http://ramblinrosecreative.com)

# Friendlier DESIGNS

## Durable PVC Big Game Passage

**Installing PVC pipe over bunched fence wires is an inexpensive way to allow elk, deer, and pronghorn to freely cross existing barbed wire fences with minimal risk.** This design is especially useful where elk, moose or other ungulates cross heavily traveled roadways and have difficulty crossing a fence, delaying their movement out of danger – particularly in spring and summer when calves are small. Along roads, the PVC passage should be installed on both sides of the right-of-way.

*PVC pipe threaded over bunched fence wires creates an effective and durable big game passage, especially on road rights-of-way.*



*Photo: Montana Fish, Wildlife and Parks*

### PVC GAME PASSAGE FOR WIRE FENCE CONSTRUCTION

These instructions are for a metal t-post, 5-strand barbed wire fence, with no livestock present, but can be adapted for other situations.

#### Materials:

To modify two 60 ft (18.3 m) sections of barbed wire fence:

- Twenty 10 ft (3 m) sections of 1.5" (38 mm) OD PVC pipe
- One 100-count bag of large (7 or 11"; 18 or 28 cm) UV-resistant plastic cable ties
- #16 or larger gauge soft wire
- Fencing pliers, wire cutter, leather gloves

#### Before Installation:

With a table saw, cut a 1/4" (6–7 mm) slot the entire length of each PVC pipe.

#### Installation:

**Step 1:** Remove all wire clips from about 60 ft (18 m) or three fence posts and allow wire to hang freely.

**Step 2:** Beginning near first post with clips removed, grip the top three strands of wire and pinch together. Locate a space between barbs that will allow you to thread on the PVC pipe.

Push pipe onto wire (not wire into pipe) concentrating on fore-end of pipe. If the pipe gets hung up on a barb at the fore-end, work barb into end of pipe and continue. Once the pipe has been adequately started, grip pipe near the fore-end and begin pulling down the length of the wire. The wire will feed itself into the pipe. Pull pipe down the wire until about 8 ft (2.5 m) from where posts with clipped wires resume.

**Step 3:** Repeat with three more PVC pipes. Space the joint between two pipes at a post where possible. This will allow you to clip the three wires together to a post.

**Step 4:** The last (fifth) pipe must be installed in the reverse direction. Starting near the end of the fourth pipe, find a space between barbs and install pipe as in Step 2, push into place 8 ft (2.5 m) from where posts with clips resume.

**Step 5:** Repeat steps 2 through 4 with the bottom two wires.

**Step 6:** Using #16 or larger soft wire, attach the top PVC pipe to posts no more than 40" (1.02 m) above the ground. Attach the bottom pipe at 18" (46 cm) above the ground or dropped closer the ground to create a larger middle gap for deer fawns/elk calves to go through rather than under. Where a joint between pipes is located at a post, enough space can be left to clip the wires to the post.

**Step 7:** Attach three cable ties on each section of PVC pipe, one near each end and one in the middle. Squeeze PVC pipe while pulling cable tie tight. Gap from cut will not be completely closed but will be small enough to allow the pipe to roll and not work its way off the wire. Clip tag end of cable tie.

**Step 8:** Repeat on opposite side of road right-of-way.



An elk herd races to cross a highway. Animals are especially vulnerable to tangling when alarmed or crowded by others.



Photos: Shawn Bryant

# Friendlier DESIGNS

## Adjustable Wire Fence

**Adjusting the height of one or more wires is an easy and effective way to allow animals to cross during migration periods when livestock aren't present.**

Drop the top wire to the level of the second wire, either in sections or along an entire run of fence, to allow wildlife to jump over easily. Note, this simple solution only works on fence runs without fence stays.

Lowering the top wire to 25" (63 cm) or less allows elk and deer and their young to hop over easily in almost all conditions. Raise the lowest wire in the same way to help wildlife crawl under. A simple staple lock or fence clip on the posts allows wires to be rapidly adjusted by only one person. As an alternative to staples, a variety of fence clips for steel or wood posts are available commercially from Tin Cup Creek Fence, [tincupcreekfence.com](http://tincupcreekfence.com).

Another simple option is to use two to three quick clips to clip the two bottom wires and two top wires together, allowing animals to slip under or jump over more easily.



### STAPLE LOCK FOR WOODEN POSTS

- Install two fence staples horizontally and less than an inch apart on each post at the level of both the top wire and the second wire.
- Slip the fence wire between the two staples.
- Secure it in place by hooking a third staple through the paired staples vertically, like a latch.

## ADJUSTABLE FENCE FOR SEASONAL WILDLIFE PASSAGE

Illustrations: Kristen Rumbolt Miller

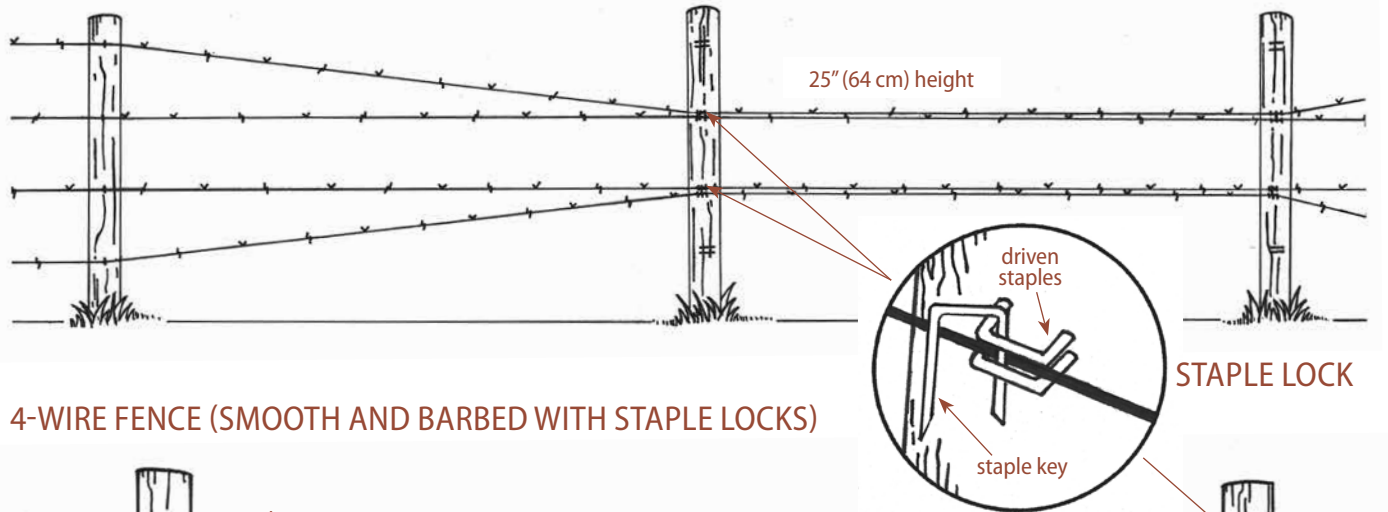

## 4-WIRE FENCE (SMOOTH AND BARBED WITH STAPLE LOCKS)

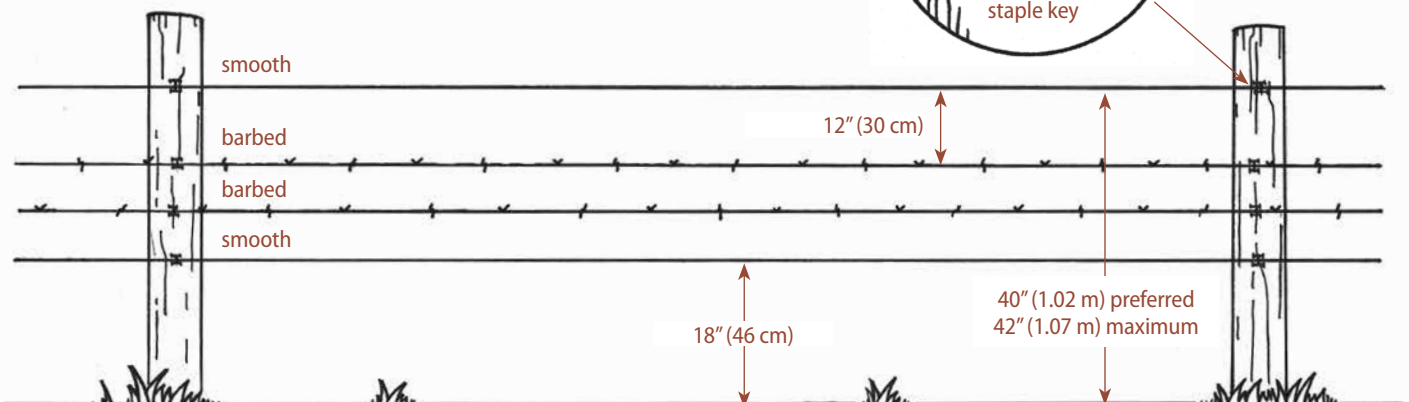



Deer will regularly go under the bottom wire of a fence when not alarmed and when the bottom wire is 18" from the ground.

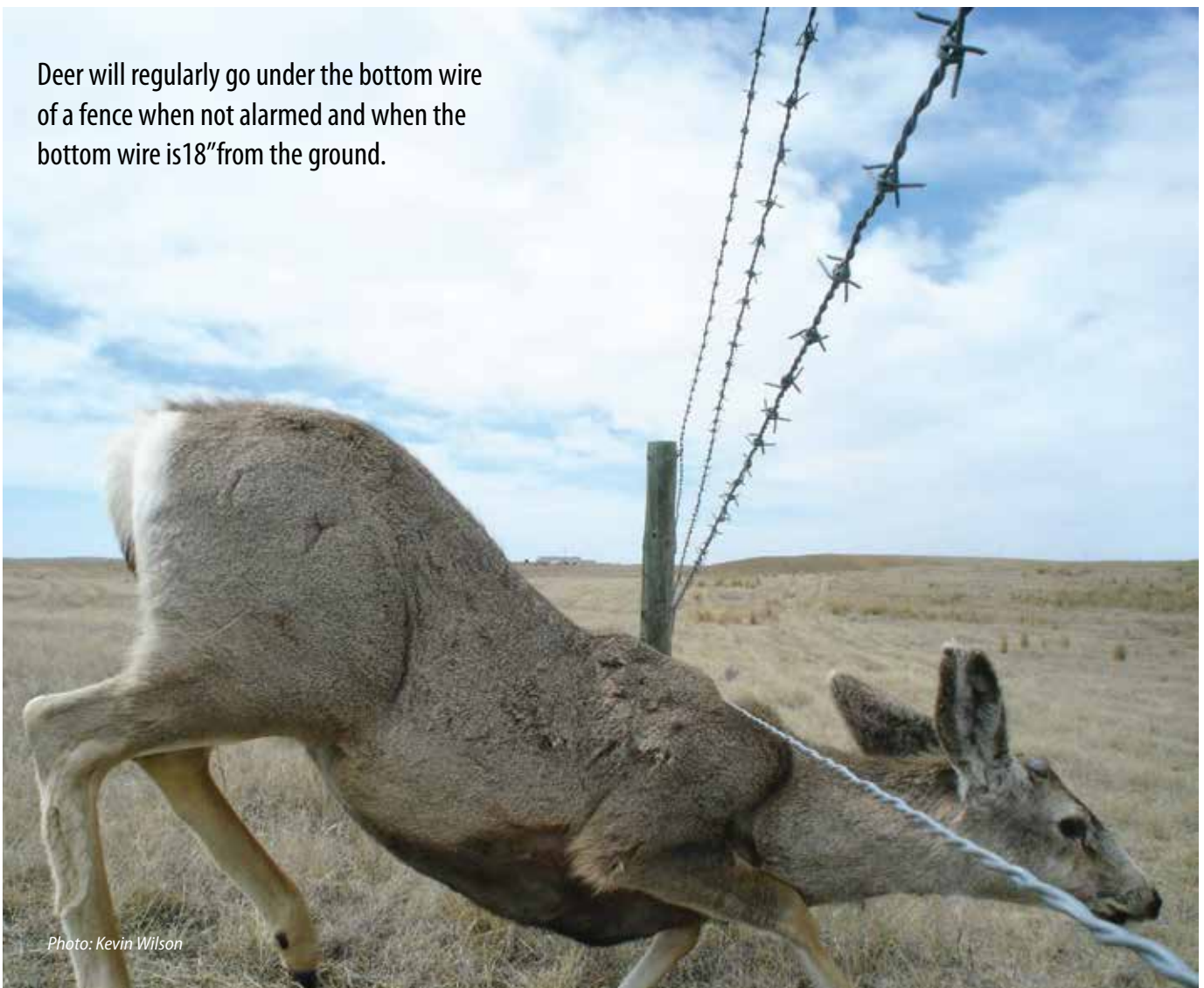

The rich native grasslands of southern Alberta are home to approximately 18,000 pronghorn. Moving with the seasons, some of Alberta's "speed goats" can cover up to 180 to 500 miles (300–800 km) in their annual migrations, some crossing into Saskatchewan and Montana and back.



## Giving Pronghorn Room to Roam

Adapted to running across expansive open grasslands, pronghorn are reluctant to jump fences and prefer to squeeze under. They can be blocked entirely by impermeable fences and seriously wounded crossing under barbed wire. Since 2009, ranchers and volunteers have come together with the Alberta Fish and Game Association (AFGA) and Alberta Conservation Association (ACA) to give pronghorn more room to roam.

The Pronghorn Corridor Enhancement Project (or simply the Antelope Fencing Project) is a joint effort to modify fences so pronghorn can slip under easily without injury and move more freely across the prairies. Project funding comes from the ACA's Grant Eligible Program and the Minister's Special Licence Fund, and the NGOs work with willing landholders to target fence projects throughout southern Alberta at no cost to the landholder.

Using data on the movements of radio-collared pronghorn, ACA identifies movement corridors and critical habitat and targets sites that block pronghorn movement. AFGA provides the logistical planning and fencing materials and brings in volunteers to tackle fence removals and modifications.

The goal is a fence that pronghorn can slip under easily with at least 18" (46 cm) between the ground and bottom wire. The bottom barbed wire is replaced with double-stranded smooth wire to reduce injuries, scarring, and hair loss on the animals' backs caused by the barbs, which in turn can increase pronghorn survival.

Page wire fences, which present a complete barrier to movement, are replaced with 4-strand wire fence that has a double-stranded smooth wire on the bottom at 18" (46 cm), plus three barbed wire strands with the top wire no higher than 40 to 42" (1.02–1.07 m). Where possible, the project modifies entire runs of fence so pronghorn can freely pass under at any point, instead of only at limited crossing sites.

The Antelope Fencing Project targets three fence projects each year, with a goal of modifying 10 miles of fence in a weekend and about 30 miles each season. Since 2009, project volunteers have opened

up 200 miles of fence for pronghorn, and completely removed another 25 miles of obsolete page wire fence. Nearly 80% of the projects have been on private ranches.

"Landholder buy-in has been incredible," reports T.J. Schwanky, Wildlife Projects Facilitator for AFGA. "The project works well because we keep it simple – we work on a handshake, and there is no further responsibility for the landholder."

AFGA and the volunteers have the process down to a science. AFGA and ACA staff recon the site beforehand, laying out all of the wire needed. On the weekend the volunteers arrive, and with 4 people per crew the work goes smoothly. FenceFast Ltd. donated three power staplers to the project, plus staple pullers and all the staples needed each season. The power staplers allow the crews to work quickly and has doubled the miles of fence that can be modified in a weekend.

"In a given year we have about 30 volunteers, and we have about an 80% return rate," says Schwanky. "Most of

our volunteers are in their 60s. A typical workday is five or six hours with a long lunch break, lots of camaraderie, and time to enjoy the landscape."

The volunteers are essential to getting the work done, but there are rewards for everyone involved. "We've had really diverse groups and the project provides a connection between urban and rural people, with everyone working together for wildlife. And sometimes volunteers have been out stapling fence and see a pronghorn cross just behind them."

For more information on this project, contact T.J. Schwanky, Wildlife Projects Coordinator, Alberta Fish and Game Association.



# Friendlier DESIGNS

## Pronghorn Underpass

Although capable of jumping even high fences in extreme situations, pronghorn prefer to crawl under fences, and almost seem unaware of their ability to “high jump.” They will often run for miles looking for fence openings or spots to crawl under a fence and have been known to die of starvation when blocked by a fence they see as impassable.

### In Sheep Range:

Pronghorn have the greatest difficulty negotiating sheep fence, which either uses lower barbed wire strands than cattle and horse fence or is typically made of page wire. However, a pronghorn “underpass” can be created by raising the bottom strand in selected fence sections.

- For sheep, space wire strands at 10–16–22–32” (25–48–56–81 cm) above the ground, the top three strands barbed wire, the bottom strand smooth wire.
- In selected sites, raise the bottom wire to the height of the third wire, securing in place with a staple lock on the posts, or with mini carabiners or quick-clips on the wires. If needed, the bottom wire can be dropped again when sheep are present.



*Pronghorn tend to use the same trails and fence crossings habitually. You can make negotiating fences easier by raising the bottom wire at known crossing sites.*

## PRONGHORN UNDERPASS FENCE WITH RAISED WIRE

Illustration: Kristen Rumbolt Miller

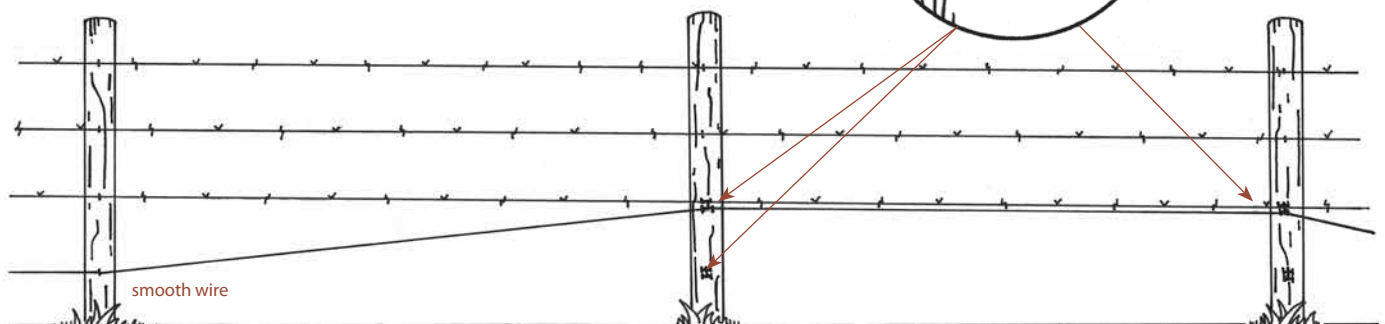



Barbed wire can cause serious scarring and hair loss on animals' backs and necks. While a PVC pipe can protect from scarring, simply raising the bottom wire with quick clips can also ease passage. Underpasses are most effective when placed where animals habitually cross.

**In Cattle and Horse Range:**

A pronghorn underpass can be created easily in a single fence section by raising the bottom wire up to the next highest wire with staple locks on the posts to make a higher clearing for pronghorn of any age to crawl under. An even simpler alternative is to use 1 to 2 inexpensive quick clips or small carabineers to clip the bottom wire to the next highest wire. **To be most effective, place the underpass where pronghorn habitually cross.**



Photos: ACA



*Staple locks allow sections or a run of fence to be quickly altered for wildlife passage. As an alternative, small oval quick clips can be used to pull the two top wires and/or the bottom wires together in each section of fence.*

**PRONGHORN UNDERPASS WITH QUICK CLIPS**

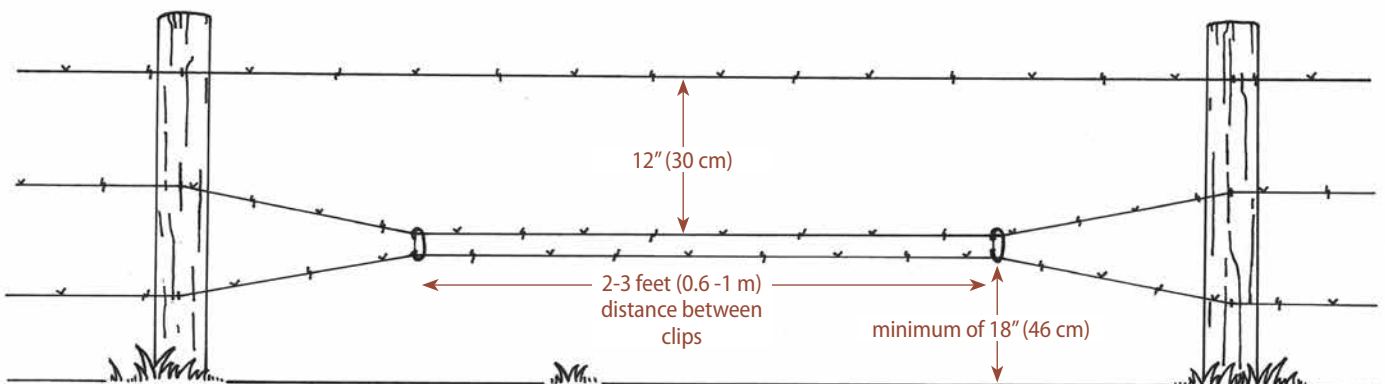

Credit: Kristen Rumbolt Miller

# Friendlier DESIGNS

## Lay-down Fence

**A lay-down fence is a standard 3- or 4-wire fence that can be laid on the ground as a unit to allow ungulates to pass through during migration or seasonal use.** A lay-down fence can reduce wildlife damage and save maintenance costs. Most designs allow a single person working alone to easily let the fence down or put it back up in a short time.

Lay-down fence can be constructed from smooth wire or barbed wire. Fence posts can be wood or steel, but treated wood is more durable in heavy snow areas. To be most effective for elk and reduce fence damage, install lay-down in at least 4 to 6 sections of fence. In areas with heavy elk migration or winter use, entire fence runs can be installed with lay-down fence to minimize wildlife fence damage.

Space posts at 16.5 ft (5 m) intervals. For barbed- or smooth-wire fence, one or two stiff fence stays are needed between fence posts, evenly spaced, plus a stay lined up with each fence post. Wood, fiberglass, composite, or steel stays can be used – do not use bendable wire stays. Wire loops, secured at the top and bottom of the fence posts, support the fence stays. **Be sure the fence stays do not touch the ground.** The lay-down section can then be dropped by flipping up the top loop and lifting the stays out of the bottom loop.

A lay-down fence can be quickly dropped or erected by a single person as needed.

### WIRE LOOP

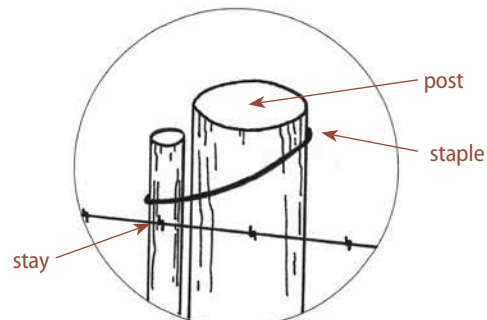

### LAY-DOWN FENCE

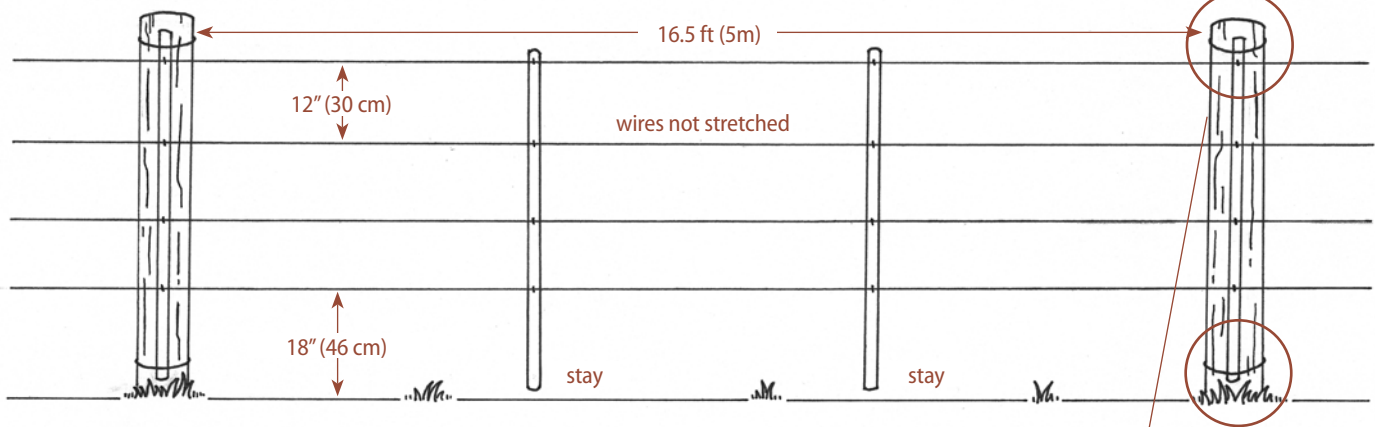

Illustrations: Kristen Rumbolt Miller

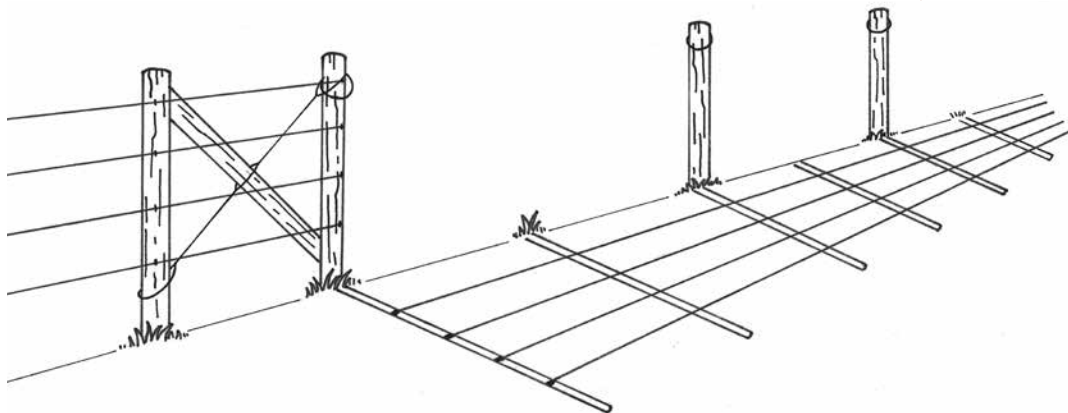





Photo: Montana Fish, Wildlife and Parks

*This lay-down fence using 4-strand smooth wire was constructed along 1.5 miles (2.4 km) of fence line next to the Blackfoot-Clearwater Wildlife Management Area in Montana to allow winter passage for elk. The number of elk tracks attest to the design's success.*



Photo: Jay Kolbe



Photo: Christine Paige

# Friendlier DESIGNS

## Wildlife Pass for Permanent Fence

**A durable pass can be erected in nearly any permanent fence using wood or welded metal rails.** With wood posts and rails, rails can be installed using anchor bolts and heavy-duty wingnuts to allow seasonal adjustments if needed. This type of wildlife crossing is especially useful wherever there are not small livestock, or in page wire, chain link, or other impassable types of fence. The top rail should be set at 38" (97 cm) and no higher than 42" (1.07 m). Allow at least 18" (46 cm) between the ground and bottom rail, and preferably higher: unlike wires, rails have no give as animals crawl underneath.



## Dropped Rail Wildlife Passage

Tall post-and-rail fence, buck and rail fence, and wooden worm fences can be difficult for animals to negotiate. An occasional gap in the fence can provide a crossing. Drop a top rail where there are signs of wildlife movement, such as game trails, and in pasture corners, stream corridors, gullies or other natural funnels.

Installing the top rail with anchor bolts and wingnuts makes it quick work to alter the rail seasonally if needed. Simply drop one end of the top rail, or the entire rail, to the ground to allow animals to step across easily. Drop rails intermittently, such as every 30 m (100 ft), in fence corners, and where wildlife trails and water access exist.



## DROPPED RAIL FOR WILDLIFE JUMP

A top rail can be dropped on one end or lowered to the ground entirely. Installing a top rail with anchor bolts and wingnuts makes it easy to alter the rail seasonally.

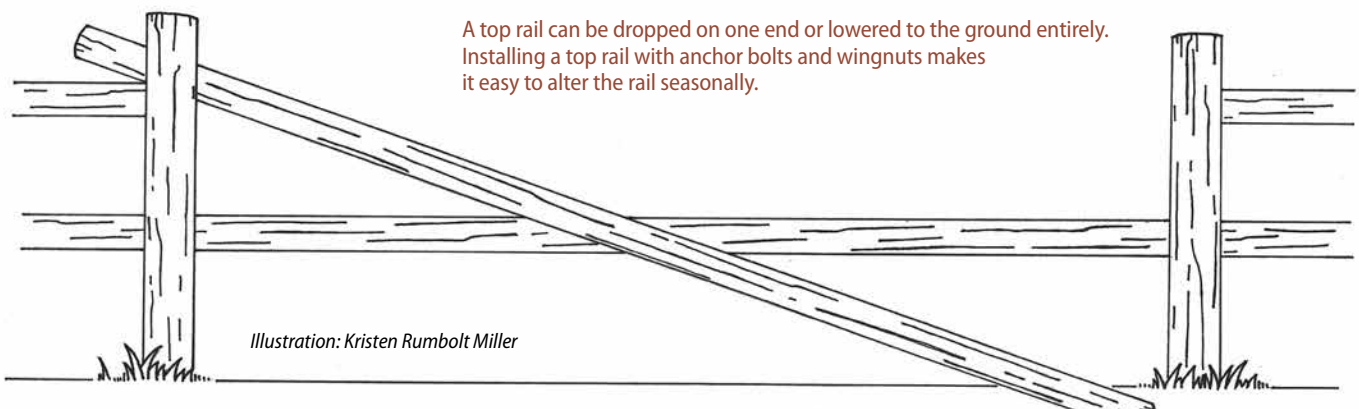

## One-way Gate

Some highway departments have successfully used one-way gates to allow animals to escape a fenced right-of-way but prevent them from re-entering. This design is used with tall enclosure fence and requires some manufacturing. The gate is constructed with formed poles or tines on spring-loaded hinges, which allow animals only one direction of travel. The gate should be placed in a funnel or corner to guide the animals out.

Some large animals can bend the tines when trying to push through from outside the gate. To reduce injury, the tines may be curved back on themselves, but animals sometimes tangle their legs in the curved tines. Instead, install plastic disks or balls on the ends of tines to prevent injury (Huijser et al. 2015).

One-way fence gates are used in some areas to allow moose, elk, deer, and other animals to escape highway rights-of-way.



Photo: Edmund Fogels

### ONE-WAY FENCE GATE

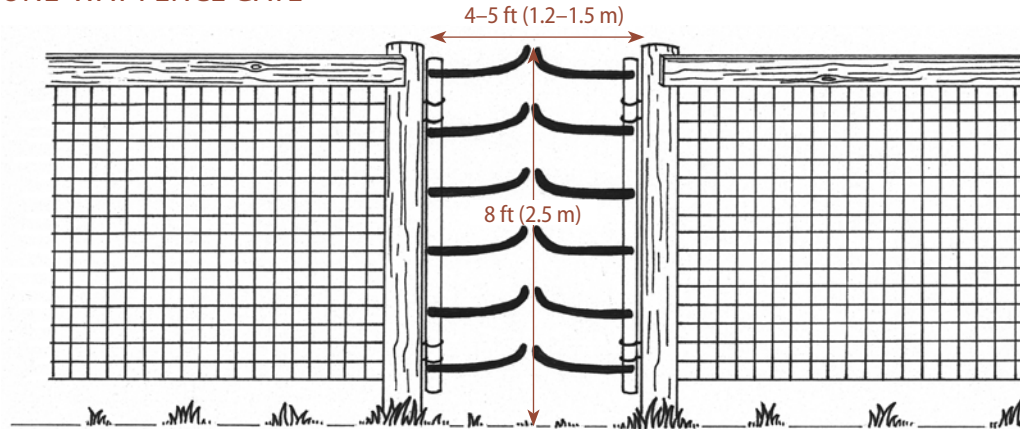

Illustration: Kristen Rumbolt Miller

## Don't Forget the Humans

Consider installing fence crossings for people, especially if the fence is on or adjacent to public lands or if you allow public access across your property. It will help preserve your fence and promote goodwill. Gates are one obvious choice, although gates are sometimes left open inadvertently. Two other options keep the fence secure and are easily installed: a wooden stile over a fence or a v-gate that prevents livestock from squeezing through but allows humans and smaller animals to pass.



Photo: Christine Paige



Photo: ACA

A V-gate or fence stile will allow humans on foot to cross easily, without the risk a gate will be left open inadvertently.



Photo: ACA, Tyler Johns

# Remedies for EXISTING FENCES

## Are you constantly repairing the same section of fence? How can you make existing fences more wildlife friendly?

Fence maintenance and modifications can significantly reduce wildlife damage. If you don't plan to replace an existing fence, alter individual sections to wildlife friendly standards to create crossings and easier passage.



Photo: ACA, Tyler Johns



Photo: ACA, Garret McKen

### Maintenance:

- Keep wires tight. Sagging wires and neglected fences create a hazard for both domestic animals and wildlife. Loose wires can snag and snare animals as they attempt to cross – tight wires reduce the chance of entanglement.

### Modifications:

- Replace barbed wire with double-stranded smooth wire, especially for top and bottom strands. Smooth wire reduces snaring and fatal entanglements.
- Adjust the height of top wire to 40" (1.02 m) and a maximum of 42" (1.07 m) above the ground.
- Increase the distance between the top two wires to 12" (30 cm) to reduce entanglements.
- Reduce the number of wires to three, or at most four.
- Add a top rail, high visibility top wire, a PVC cover on the top wire, or flagging to increase visibility.
- Raise the bottom wire to 18" (46 cm) above the ground to allow animals to slip under.
- For pronghorn, create underpasses by pulling the bottom wire up to the next wire, securing with staple locks on posts or quick clips on the wires.
- Add wildlife crossings by using dropped wires, dropped rails, lay-down fence, or wildlife passes, as described earlier. Target sites where fence is often damaged, game trails are apparent, and near water.
- When livestock aren't present, secure gates open to allow free passage for wildlife.
- Provide wildlife access to rivers, streams, wetlands and water holes, and through seasonal migration areas.

### Removal:

- Remove old fences that are in disrepair or no longer in use. Remove unnecessary interior fences.
- Bale and carry away piles of wire. Some recycling centers will recycle old wire. Never leave wire on the ground.
- Many volunteer groups are interested in helping with fence removal projects to help wildlife such as local chapters of sportsman's groups, scout troops, 4-H and others.

# Remedies for EXISTING FENCES

## Wildlife “Death Pipes”

**Open vertical pipes are silent and overlooked killers of birds and small animals. Hollow metal and plastic (PVC) pipes serve a wide variety of purposes, from fence posts, corner posts, and gate uprights to mining claim markers and ventilation pipes for buildings, outhouses, or irrigation systems.**

Birds, small mammals, and reptiles will investigate hollow pipes, especially for potential nest sites. Once inside they become fatally trapped, unable to find purchase on the pipe’s smooth walls. For example, a biologist at the Audubon California Kern River Preserve found more than 200 dead birds in a fallen 50-year-old irrigation standpipe.

Most victims are cavity-nesting birds, such as bluebirds, woodpeckers, kestrels, and small owls. Because open pipes are so prevalent across our landscapes, the overall toll on birds and small animals may be in the millions.



Photos: Sean Rowe

*Cap or screen open vertical pipes to prevent birds and other small animals from becoming fatally trapped.*

### EASY FIXES FOR DEATH PIPES

- Remove unused obsolete pipes.
- Permanently cap or fill pipes used as fence posts, gate uprights, signposts, claim markers, or monuments. These can be capped with concrete, or entirely filled with sand, gravel or concrete. Chainlink fence posts can be capped with commercial caps.
- Cover ventilation pipes on buildings, irrigation systems, and outhouses with galvanized hardware cloth held in place by steel pipe clamps or install commercial vent caps.



## Other Remedies

### Wire Mesh Cages to Protect Trees from Beaver

The simplest method to prevent beaver from harvesting trees is to install a cylindrical mesh cage around tree trunks. Heavy gauge rolled hardware cloth or mesh fencing is available from most ranch supply and hardware stores.

#### WIRE MESH CAGE

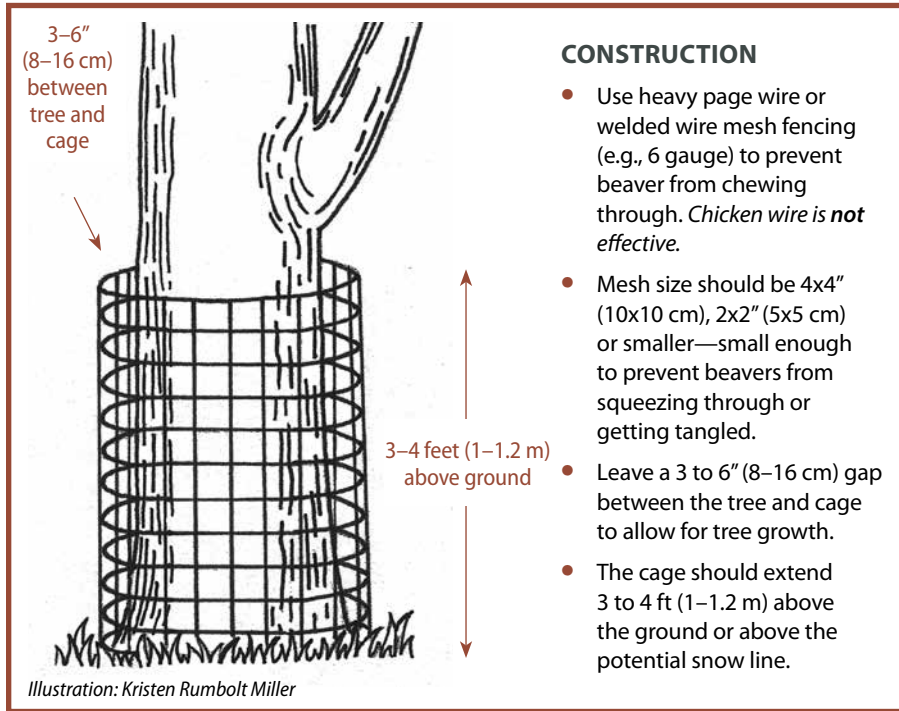

# Acreage Fences & ALTERNATIVES

**Fences serve many functions around homes, both aesthetic and practical: they may define a boundary, create a play space, contain pets, or discourage wildlife from yards and gardens.** Check city and county ordinances for fence regulations.

Tall residential fences, whether wrought iron, plank, or chain-link, should only be used for small areas with a specific purpose, and not for larger perimeter fences. Be sure vertical planks or bars are spaced closely enough that animals will not try to push through and become trapped. Avoid fences with spikes or pickets that protrude above the top bar. Animals can misjudge the fence height and be impaled on the fence. If a fence creates a complete barrier, an open gate may allow animals to find a way in but not out. Keep gates closed or provide passages for wildlife.

Many residential areas are in wildlife winter range. Using landscaping instead of fencing, or using only low, very permeable fences, allows wildlife to move freely through neighborhoods.



*Photos: Christine Paige*



*A low rail, post and cable, or post and chain fence can define a yard but poses little hazard for wildlife as long as it's easily seen.*





*A page wire yard fence with top rail no higher than 42" (1.07 m) poses little barrier to adult mule deer.*

*Photo: Christine Paige*

## HEDGEROWS

**If you do not need a fence to contain or exclude livestock, contain pets, or exclude wildlife, consider other creative ways to define boundaries and discourage trespass.**

A line of shrubs or trees can mark a boundary line, beautify your landscape, and create wildlife habitat. Hedgerows provide nest sites, food, and cover for birds, pollinators, and other wildlife.

Depending on the site, a wide range of native and ornamental shrub species can be used to create an effective hedgerow—from honeysuckle to willows, alder, and big sagebrush. Many native plants are suitable for hedgerows, enhance wildlife habitat, support endemic pollinators, and are better adapted to local climate and soils. **Beware using some non-native species that can become difficult or impossible to manage.**

Mix it up: consider using several species, varying the width of the hedgerow, and using trees, shrubs and perennials of different heights to create a natural and wildlife friendly hedge. Once established, hedgerows require minimal maintenance unless you desire a highly manicured look.



*Photo: lillisphotography*

*A 7 to 8 ft (2 to 2.5 m) fence is an effective barrier to elk, but should be used only for specific needs, such as gardens or haystack yards. Make the top highly visible with flagging, white tape or wire, or a rail, and never top with barbed wire.*



Photo: Christine Paige

# If You **MUST EXCLUDE**

**There are times when exclusion fence to keep wildlife out is necessary.** If you must put up an exclusion fence, avoid fencing a large area that includes wildlife habitat. Focus exclusion fences on small areas for specific purposes, such as fencing around play areas, pet runs, vegetable gardens, beehives, calving and lambing areas, or haystacks. Keep exclusion fence close to the activity you need protected and allow wildlife to use other parts of the property.

For any exclusion fence, place gates at corners: an animal that inadvertently finds itself trapped inside is more likely to find escape through an open corner gate than through a side gate.

## Chainlink and Wooden Plank Fence

Chainlink fences and wooden fences with closely spaced vertical planks are especially unfriendly to wildlife and can create a complete barrier to animals of all sizes, from turtles to moose. If you must use chainlink or plank fences, limit their use to small enclosures.

Yard fences and play area fences often do not need to be more than 4 ft (1.2 m) high. If higher, be sure gates are kept secured to prevent animals from finding their way in. For small chainlink dog kennels, attach a roof to prevent wild animals from becoming trapped inside. A roof also provides shade and shelter for your pets.

## Deer and Elk Exclusion Fence

A permanent non-electric exclusion fence for deer and elk should be 7 to 8 ft (2.1–2.4 m) high. A high fence with wood slats or other privacy screen that animals can't see through is usually used only around housing areas.

For gardens, vineyards, and other agricultural plots, an 8 ft (2.4 m) page wire fence can be used with posts set at 8 to 20 ft (2.4–6 m) intervals and the page wire brought tight to the ground. Make the top highly visible by using high-visibility wire, flagging, or a top rail. Place gates at corners, where an accidentally trapped animal is more likely to find an escape.

*Use chainlink fences only for specific purposes, such as play areas and dog kennels.*



*Photo: Christine Paige*



*Photo: Getty Images/iStockphoto*

# If You MUST EXCLUDE

## Haystacks and Hay Yards

Several options exist for protecting haystacks from wildlife damage. These include electric, non-electric, temporary and permanent designs.

### Temporary Solutions

A simple and cost-effective solution is to wrap haystacks with heavy-duty plastic mesh netting such as Deer-D-Fence, a 2x2" (5x5 cm) durable plastic mesh that is strong, lightweight, and easy to handle. Haystacks and large bales can be wrapped quickly, and the netting is readily lifted off when not needed. This netting is especially useful for temporary applications, rapid installation, and remote settings.

Plastic netting can also be used as fencing instead of page wire and installed on wood or steel posts using UV-resistant zip-ties. The plastic is UV-resistant and durable, and materials cost is comparable to page wire. However, labor costs for fence construction can be greater than with traditional materials. Increase visibility by adding poly-coated wire, tape or flagging when using plastic mesh as fencing. Although the mesh would cause little harm to most large animals, it is nearly invisible when erected and should be flagged to be visible to birds.



*Photo: Montana Fish, Wildlife and Parks*

*Deer-D-Fence plastic netting can be used to temporarily protect haystacks.*

A traditional 8 ft (2.4 m) page wire fence can protect a stackyard from game damage. An alternative is a permanent 7-strand electric fence.

*Photo: Christine Paige*



## Permanent Fences

Many landholders prefer to protect a large haystack yard with a permanent fence. The traditional stackyard fence is at least 8 ft (2.4 m) high and uses page wire with wood posts or a combination of wood and steel posts. One-way gates should be placed in the corners to allow animals that might be inadvertently trapped inside to find a way out more easily.

A permanent electric fence 6 to 7 ft (1.8–2.1 m) high is also effective for protecting stackyards from game damage. This fence is constructed with high-tensile smooth wire spaced at 10" (25 cm) intervals with alternating hot and grounded wires.

A 7-wire fence 72" (1.83 m) high with strands at 10" (25 cm) intervals is adequate for elk. However, deer require a higher fence of 84" (2.13 m), with 8 to 9 wires.

### PERMANENT ELECTRIC HAYSTACK FENCE CONSTRUCTION

- Line posts: use 10 ft (3 m) pressure-treated wooden line posts, 3 to 4" (7.6–10 cm) in diameter, driven 2.5 ft (75 cm) into the ground, and spaced at 30 ft (9 m) intervals.
- Brace posts: use 10 ft (3 m) pressure-treated wooden brace posts, 4 to 5" (10–13 cm) in diameter, driven 3 ft (90 cm) into the ground.
- Use 12.5-gauge, smooth Class III galvanized wire with a tensile strength of 170,000 PSI and breaking strength of 1308 lbs. To increase visibility, use white poly-coated wire with the same specifications.
- Space seven strands at 10" (25 cm) intervals; the top wire at 72" (1.83 m) for elk or 84" (2.13 m) for deer.
- Wooden posts require using insulators.
- Alternate hot and ground wires: bottom wire is grounded, and top two wires are hot.
- Install cut-off switches on lower wires if they may become buried in snow.
- Remove shrubs and vegetation that may contact wires, especially under snow.
- Place solar energizer according to manufacturer recommendations.
- Ground fence properly according to the energizer instructions.
- Install electric fence warning signs.



Photo: Montana Fish, Wildlife and Parks



Photo: Montana Fish, Wildlife and Parks

A permanent electric haystack fence is an effective alternative to a page wire fence. A 6 ft (1.8 m) fence with 7 strands at 10" (25 cm) intervals is adequate for elk. Vegetation, cold temperatures, and snow can create issues for electric fence, so check voltage and condition regularly.



*Photo: Christine Paige*

## Carnivore Solutions

Large predators pose unique risks and challenges to communities in working landscapes. In southwestern Alberta, ranchers and farmers share the land with grizzlies, black bears, wolves, and cougars, and as carnivore populations increase so do conflicts. Predators pose a safety concern, and at times kill livestock and pets. Bears will break into a wide assortment of attractants in their hunt for food and do costly damage to crops, silage, grain bins, and farm buildings.

Jeff Bectell runs a cow/calf operation 14 miles east of Waterton Lakes National Park on land that has been in his family since 1917. After completing a degree in Zoology at the University of Calgary, Bectell came back to the ranch and, as conflicts with grizzlies in the area began to increase, he got involved with community meetings to find solutions.

Bectell believes that coexistence between people and carnivores is easier when landholders are supported in efforts to reduce conflict with predators on agricultural operations. A 2009 survey by the Waterton Biosphere Reserve Association (WBRA) revealed that a majority of residents in the region feel the same. Bectell is a current board member of WBRA and coordinator of the Waterton Biosphere Reserve's Carnivores and Communities Program (CACP)—a program devoted to community-based solutions to carnivore conflicts.

Since 2009, the CACP has worked across southwestern Alberta to help farmers and ranchers reduce conflict with large carnivores, reduce the economic impact of conflicts, and increase people's safety. The program has completed more than 70 projects on ranches and farms, such as securing grain and feed with bear-proof granaries and Sea Cans (steel shipping containers) and working out solutions for deadstock removal. Predator-proofing also often includes electrified fence solutions to keep animals out of grain bins, night pens, calving areas, stack yards, bee yards, and silage bales.

There is no one-size-fits-all remedy to carnivore conflicts, and the CACP relies on cost-share partnerships, sharing knowledge, and landholder-driven projects to create results. "We try to be non-

prescriptive when we design projects, and present different options to the landholder," explains Bectell. Topography, infrastructure, and wildlife species are all factors in customizing solutions, and it can take trial, error, and gradual adjustments. "Yet basic principles always apply," says Bectell, who shares some of the success stories achieved by the CACP.

A 6-wire fence with alternating hot and ground wires is the go-to electric fence design to deter bears and wolves and can be tailored for different situations. For example, after several years of bear conflicts, Clarence and Helen Cyr of Valley Blue Ranch installed a 6-wire braided cable electric fence to protect their grain storage. Built under a cost-share project with WBRA and other partners, the fence effectively prevented further bear intrusions and is still in use today.

Tony and Lorraine Bruder own and operate Twin Butte Simmentals, the third generation on their family ranch. Timbered river bottoms serve as corridors for grizzlies, black bears, wolves, and cougars. They've

lost stock, and also lose production to weight loss when predators chase their livestock. In 2010, when two cows were killed in the calving pasture, the Bruders designed and installed a five-wire high-tensile electric fence to protect a pen for spring calving and silage feeding. A cost-share project with the Drywood Yarrow Conservation Partnership, they've found their five-wire fence to be effective for wolves and bears. The Bruders have also undertaken other mitigation projects to deter carnivores, step by step bringing about changes to how they run their operation and steward the land.

By working with the ranching communities and bringing in expertise and cost-share possibilities from a wide range of partners, the CACP is helping create a future for both people and large carnivores in southwestern Alberta. More details on CACP projects and opportunities can be found at <https://www.watertonbiosphere.com>, where you can also download the CACP's Technical Guides, *Electric Fencing and Securing Your Grain Storage*.



Photo: Getty Images/iStockphoto



Photo: Getty Images/iStockphoto



# Deterring PREDATORS

**A variety of permanent and temporary electric fence designs can deter large predators.** These fences are used primarily for small-scale operations, such as beehives, dumpsters, lambing or calving areas, corrals, bone piles and other small areas in need of protection from scavenging or predation.

**A 5- to 7-wire permanent electric fence from 42 to 54" (1.07–1.37 m) high is most commonly used to deter bears and wolves.** In special situations, a higher 9-wire or 11-wire fence might be used. In dry, rocky soils, the fence should have

alternating charged and grounded wires, with both top and bottom wires hot. In this setup, an animal must touch both a hot and a ground wire to receive a full shock. Use a grounded bottom wire if the wire is likely to touch vegetation. A fence with all hot wires can be used in areas with damp or moist soils that will provide sufficient grounding when the animal touches a hot wire.

The adjacent table shows specifications developed by the NRCS in cooperation with Montana Fish, Wildlife and Parks (NRCS 2006b).

## PERMANENT BEAR AND WOLF DETERRENT FENCING

(Adapted from NRCS 2006B)

Charge and Recommended Wire Heights from Ground Level

Wire	Charge	Bear <sup>1</sup> 7-wire	Wolf & Bear <sup>2</sup> 7-wire	Beehive or Chicken Coop <sup>3</sup> 7-wire	Wolf & Bear <sup>4</sup> 9-wire (corral or home areas)	Wolf & Bear <sup>5</sup> 11-wire (away from corral or home areas)
Top	+	42" (1.07 m)	54" (1.37 m)	54" (1.37 m)	60" (1.52 m)	72" (1.83 m)
2nd	-	36" (91 cm)	42" (1.07 m)	42" (1.07 m)	50" (1.27 m)	64" (1.63 m)
3rd	+	30" (76 cm)	32" (81 cm)	32" (81 cm)	42" (1.07 m)	56" (1.42 m)
4th	-	24" (61 cm)	24" (61 cm)	24" (61 cm)	36" (91 cm)	48" (1.22 m)
5th	+	18" (46 cm)	18" (46 cm)	18" (46 cm)	30" (76 cm)	40" (1.02 m)
6th	-	12" (30 cm)	12" (30 cm)	12" (30 cm)	24" (61 cm)	32" (81 cm)
7th	+	6" (15 cm)	6" (15 cm)	6" (15 cm)	18" (46 cm)	26" (66 cm)
8th	-				12" (30 cm)	20" (51 cm)
9th	+				6" (15 cm)	15" (38 cm)
10th	-					10" (25 cm)
11th	+					6" (15 cm)

1. Bear 7-wire: Primarily to deter grizzly and black bears; allows some deer and elk passage.
2. Wolf & Bear 7-wire: Primarily to deter grizzly, black bear and wolves from calving and lambing areas, but where wolf activity is low to moderate.
3. Beehive or Chicken Coop 7-wire: Primarily to deter grizzly and black bears from apiaries.
4. Wolf & Bear 9- or 11-wire: Primarily to deter wolves and bears when predator activity or risk is high. Also useful for where ungulate damage to a lower fence (54" or 1.37 m) might be anticipated.



Photo: Christine Paige

*Predator deterrent fencing should be used only around specific areas, such as corrals and beehives. Always hang warning signs on electric fences.*



Photo: Seth Wilson



Photo: Seth Wilson

# Deterring PREDATORS

Some producers are experimenting with temporary 3- to 4-wire electric fence to deter bears and reduce conflicts in areas such as crop fields. The advantage is a streamlined and economical fence. Keeping the fence perimeter small, placement for easy maintenance, and performing regular maintenance are essential. To be effective against bears, the fence wire must be all metal, such as high-tensile or braided airplane cable, to deliver an adequate jolt when tested.

Key to the success of any electric fence for predators is to erect them **before** the attractant level is high, so that animals are trained to a fence early on and before they become food conditioned. **The amount of energy your setup can deliver over the full distance of the fence is crucial.**

Because of predators' thick fur, the system must deliver enough shock to deter them, and the design should deliver the jolt to their face or nose. For grizzlies, the system should deliver 6,000 volts or more, and will require an energizer with a rating of at least 0.7 joules.

Be sure your energizer can deliver adequate power over the full distance of your fence. Vegetation touching the wires, snow drifts, and other situations can cause energy leakage or failure. Check the voltage regularly on every hot wire with a high-quality voltage tester, especially midway and at the farthest distance from the energizer. Always install warning signs on the fence.

For more complete instructions and appropriate fence designs, see *Bears and Electric Fencing* published by Montana Fish, Wildlife and Parks, available online at <http://fwp.mt.gov/fwpDoc.html?id=48893> (Annis 2014).

Also see *Practical Electric Fencing Resource Guide: Controlling Predators* published by the Living with Wildlife Foundation and available online at <https://lwwf.org/resource-guides> (Sowka 2013).

FenceFast Ltd. (<https://fencefast.ca>) offers materials and solutions for many types of electric fence, including livestock fence and deterrent fence solutions for large and small predators.



Photo: Tim Manley

Chicken coops and beehives are irresistible to bears, but a high-energy electric fence is effective protection.

## Unwelcome mats

An electrified mat, also called an "unwelcome mat," is an effective bear deterrent in front of doorways and sheds. Larger mats may have applications for drive-throughs at carcass pens and other situations.

A DIY unwelcome mat can be made using a rubber base, such as a horse stall mat, with metal 4x4" (10x10 cm) mesh wire affixed to the top, and wires attached to an energizer rated to at least 0.7 joules. Be careful that no metal goes through the mat that would ground out the system. Such a mat is safe to use – it can be walked on with rubber-soled shoes, and larger mats can be driven over with rubber tires. Be sure to install a warning sign. For full instructions, see *Unwelcome Mats* by Colorado Parks and Wildlife, available online at <https://cpw.state.co.us/Documents/Education/LivingWithWildlife/UnwelcomeMats.pdf>.



An electrified "unwelcome mat" is an effective bear deterrent. This commercial version is made by Bear Busters ([www.tahoebearbusters.com](http://www.tahoebearbusters.com)) for residential use, but DIY versions are easy to assemble from materials available at ranch supply centers.

Photo: Ryan Welch, [www.tahoebearbusters.com](http://www.tahoebearbusters.com)

## Fladry to Deter Wolves

Fladry is a line of wire strung with long flags or streamers used to deter wolves from livestock. Fladry's advantage is that it is portable, temporary, and requires comparatively little planning – it serves best as a short-term deterrent. Deployed around temporary pastures, fladry has been shown to deter wolves for up to 60 days and longer if electrified (Primm et al. 2018), however it is not effective against bears or cougars.

Fladry should be installed around as small a perimeter as possible and left in place for no more than 2 months. Like any electric fence, the voltage must stay high to remain effective, and the fence should be regularly checked and maintained. A spooler can be readily built and installed on a pickup hitch to easily deploy and roll up fladry.

See the *Fladry Manual* published by People and Carnivores for more detail on best practices and how to build a DIY spooler, available at <https://peopleandcarnivores.org> (Primm et al. 2018).

### CONSTRUCTION

- Use a large spool or reel [6" (15 cm) minimum diameter and 1" (28 cm) minimum width] to coil and deploy fladry. Handling by hand is enormously time-consuming.
- Electrified fladry ("turbo fladry") has a longer period of effectiveness and deters livestock from trampling the line.
- Use 3/8" x 4 ft (1 cm x 1.2 m) fiberglass rod posts. Carry these in an old golf bag to deploy in the field.
- Line height should be no higher than 28" (71 cm) and fladry flags should hang above the ground to minimize voltage leaks. In spring and summer, it is difficult to keep flags from touching vegetation.
- To secure the line, use a "harp clip," which allows the fladry flags to slide through the clip. See <http://www.premier1supplies.com> for an effective harp clip.
- For anchor posts, use thicker composite posts with wire clips, steel t-posts with insulators, or insulators on permanent wooden posts of existing fence.
- Create gates using anchor posts and good quality electric fence handles connected to an eyebolt on the post.
- Electrify with an energizer that will provide an output of at least one joule per mile of fladry.
- A "wide impedance" energizer will deliver more consistent voltage under adverse conditions, such as dry soils, dry snow, cold temperatures, and long insulating fur.



Photos: Steve Primm



*Reach out for help. Provincial agricultural and conservation programs, land trusts, sportsmen's clubs, community groups, and conservation organizations may be able to help with technical assistance, small grants, or staff and volunteer support on fence projects that benefit wildlife.*

# Getting **HELP**

**People and organizations like hands-on projects that enhance habitat for wildlife. Many local land trusts, sportsmen's clubs, community groups and conservation organizations may be able to provide cost-share support or volunteers for wildlife friendly fencing projects to enhance wildlife habitat on private or public lands.** For example, in southern Alberta, the Alberta Fish and Game Association ([www.afga.org](http://www.afga.org); see story on page 41) has a dedicated volunteer group that works on fence removal and fence modification projects for pronghorn. Also, the Waterton Biosphere Reserve ([www.watertonbiosphere.com/](http://www.watertonbiosphere.com/); see story on page 59) has programs to assist ranchers with fencing related to carnivore issues.

There are several provincial non-government and government organizations that may be able to assist you with technical information or funding for wildlife friendly fencing projects. Alberta Conservation Association ([www.ab-conservation.com](http://www.ab-conservation.com)) has programs that work with landholders and ranchers in central and southern Alberta and may be able to assist with fencing projects. Check with your local Watershed Council (<https://www.alberta.ca/watershed-planning-and-advisory-councils.aspx>) for technical assistance and information on landholder programs.

The goal of the Environmental Farm Plan (EFP, [www.albertaefp.com](http://www.albertaefp.com)) for Alberta agricultural producers with commitment to environmental stewardship by completing a farm plan. EFP may be a source of information through trained technicians. ALUS ([alus.ca](http://alus.ca)) is another program that works with farmers and ranchers who are producing acres of clean air, clean water, wildlife habitat, and other ecosystem services in communities across Canada. ALUS may be a source of information and may have funding opportunities for wildlife friendly fencing.

Lastly, check with your local Fish and Wildlife and Public Lands ([www.Alberta.ca](http://www.Alberta.ca)) representative for information on wildlife friendly fencing and whether they are aware of current programs to assist landholders with fencing projects. Also remember for any fencing projects on public lands, please consult with your Public Lands representative to determine if any additional requirements are needed for authorization before erecting or modifying an existing fence.



*Photo: T.J. Schwanky*



*Photo: T.J. Schwanky*

# SOURCES

- Alberta Queen's Printer. 2010.** Stray Animals Act. Revised Statutes of Alberta 2000 Chapter S-20. Alberta Queen's Printer, Edmonton, AB. <http://www.qp.alberta.ca/documents/Acts/s20.pdf>
- Alberta Queen's Printer. 2016.** Line Fence Act. Revised Statutes of Alberta 2000 Chapter L-13. Alberta Queen's Printer, Edmonton, AB. <http://www.qp.alberta.ca/documents/Acts/L13.pdf>
- Alberta Queen's Printer. 2020.** Public Lands Act – Public Lands Administration Regulation. Alberta Regulation 187/2011 with amendments up to and including Alberta Regulation 145/2019. Alberta Queen's Printer, Edmonton, AB. [http://www.qp.alberta.ca/documents/Regs/2011\\_187.pdf](http://www.qp.alberta.ca/documents/Regs/2011_187.pdf)
- Allen, G.T. and P. Ramirez. 1990.** A review of bird deaths on barbed wire fences. *Wilson Bulletin* 102(3):553-558.
- Annis, K. 2014.** Bears and Electric Fencing: A starter's guide for constructing a front country electric fence. Montana Fish, Wildlife and Parks. 13 pp. Available online at: <http://fwp.mt.gov/fwpDoc.html?id=48893>
- Burkholder, E. N., A. F. Jakes, P. F. Jones, M. Hebblewhite, and C. J. Bishop. 2018.** To jump or not to jump: mule deer and white-tailed deer fence crossing decisions. *Wildlife Society Bulletin* 42:420-429.
- Christiansen, T. 2009.** Fence marking to reduce greater sage-grouse (*Centrocercus urophasianus*) collisions and mortality near Farson, Wyoming – summary of interim results. Wyoming Game and Fish Department, Green River, WY. 3 pp.
- Colorado Parks and Wildlife.** Unwelcome Mats: help keep bears wild. Colorado Parks and Wildlife. 2 pp. <https://cpw.state.co.us/Documents/Education/LivingWithWildlife/UnwelcomeMats.pdf>
- Hanophy, W. 2009.** Fencing with Wildlife in Mind. Colorado Division of Wildlife, Denver, CO. 36 pp. Available online at: [http://wildlifefriendly.org/wp-content/uploads/2015/09/fencingwithwildlifeinmind\\_coloradodow.pdf](http://wildlifefriendly.org/wp-content/uploads/2015/09/fencingwithwildlifeinmind_coloradodow.pdf)
- Gates, C. Cormack. 2006.** Fencing guidelines for bison on Alberta public lands with wildlife and access in mind. Faculty of Environmental Design, University of Calgary, Calgary, Alberta, Canada. 8 pp. [https://www.canadianbison.ca/application/files/7214/8778/3208/Fencing\\_guidelines\\_for\\_Bison\\_on\\_Alberta\\_Public\\_Land.pdf](https://www.canadianbison.ca/application/files/7214/8778/3208/Fencing_guidelines_for_Bison_on_Alberta_Public_Land.pdf)
- George Miksch Sutton Avian Research Center. 2006.** Fence marking for lesser prairie-chickens: a cooperative conservation solution. Sutton Avian Research Center, Bartlesville, OK. 2 pp. Available online at: [https://new.suttoncenter.org/wp-content/uploads/2015/10/fence\\_marking.pdf](https://new.suttoncenter.org/wp-content/uploads/2015/10/fence_marking.pdf)
- Gillihan, S.W. 2000. Barbed wire fence fatal to burrowing owl. *Colorado Field Ornithologists*. 34(4):220-221.
- Harrington, J.L. 2005.** Characteristics of ungulate behavior and mortality associated with wire fences. Master's thesis, Utah State University, Logan, UT. 48 pp.
- Harrington, J.L., and M.R. Conover. 2006. Characteristics of ungulate behavior and mortality associated with wire fences. *Wildlife Society Bulletin* 34(5):1295-1305.
- Huijser, M., A. Kociolek, T. Allen, P. McGowen, P. Cramer, M. Venner. 2015.** Construction guidelines for wildlife fencing and associated escape and lateral access control measures. Western Transportation Institute, Montana State Univ., Bozeman, MT. 218 pp.
- Jakes, A. F. F. Jones, C. Paige, R. Seidler, and M. Huijser. 2018.** A Fence Runs Through It: A call for greater attention to the influence of fences on wildlife and ecosystems. *Biological Conservation* 227:310-318.
- Jones, P. F., A. F. Jakes, D. R. Eacker, B. C. Seward, M. Hebblewhite, and B. H. Martin. 2018.** Evaluating responses by pronghorn to fence modifications across the northern Great Plains. *Wildlife Society Bulletin* 42:225-236.
- Jones, P. F., A. F. Jakes, A. M. MacDonald, J. A. Hanlon, D. R. Eacker, B. H. Martin, and M. Hebblewhite. 2020.** Evaluating responses by sympatric ungulates to fence modifications across the Northern Great Plains. *Wildlife Society Bulletin DOI: 44:130-141.*
- Jones, P. F., A. F. Jakes, A. C. Telander, H. Sawyer, B. H. Martin, and M. Hebblewhite. 2019.** Fences reduce habitat for a partially migratory ungulate in the Northern Sagebrush Steppe. *Ecosphere* 10:e02782.
- Jones, P.F., B. Seward, L. Seward and H.M. Dorchak. 2012.** Opening up the prairies: evaluating the use of goat bars by pronghorn. Pp. 52-58 in Walker, R. N., and K. W. Rodden, eds. *Proceedings of the Twenty-fifth Biennial Western States and Provinces Pronghorn Workshop*. New Mexico Department of Game and Fish, Santa Fe, USA.
- Karhu, R. and S. Anderson. 2003.** Evaluation of high-tensile electric fence designs on big game movements and livestock containment. Final Report April 2003. Wyoming Cooperative Fish and Wildlife Research Unit. Laramie, WY. 27 pp.
- Karhu, R. and S. Anderson. 2006.** The effect of high-tensile electric fence designs on big-game and livestock movements. *Wildlife Society Bulletin* 34(2):293-299.
- Karsky, Dick. 1988.** Fences. Publication #8824 2803. U.S. Department of Agriculture, Forest Service, Missoula Technology and Development Center, Missoula, MT. 210 pp. Second printing 1999. Available online at: <http://www.fs.fed.us/eng/pubs/pdfpubs/pdf88242803/pdf88242803dpi300.pdf>.
- Montana Dept. of Fish, Wildlife and Parks. 2002.** Fencing specifications for FWP properties. Internal document. 4 pp. MT Dept. of Fish, Wildlife and Parks, Helena, MT. October 25, 2002.
- Nero, R.W. 1974.** Great gray owl impaled on barbed wire. *Blue Jay* 32(3):178-179.
- Nesbitt, S.A. and D.T. Gilbert. 1976.** Powerlines and fences hazards to birds. *The Florida Naturalist*. April: 23.
- North Dakota Game and Fish Dept. 2006.** Pronghorn management guide-2006: Biological and management principles and practices designed to sustain pronghorn populations from Canada to Mexico. North Dakota Game and Fish Department. 158 pp.
- NRCS. 2006a.** Natural Resources Conservation Service Conservation Practice Specification: Permanent Power Fence. Code 382(b)-1 of 5. May 2006. Natural Resources Conservation Service, Wyoming. 7 pp.
- NRCS. 2006b.** Natural Resources Conservation Service General Specification Power Fence. Fence (Feet) Code 382. Specification MT-382 (Power Fence), April 2006. 3 pp. Natural Resources Conservation Service Montana.
- NRCS. 2010.** Animal Enhancement Activity –ANM27 – Wildlife friendly fencing. Natural Resources Conservation Service. 2 pp.
- Paige, C. 2012.** A Landowner's Guide to Wildlife Friendly Fences. Second Edition. Private Land Technical Assistance Program, Montana Fish, Wildlife & Parks, Helena, MT. 56 pp.
- Paige, C. 2015.** A Wyoming Landowner's Handbook to Fences and Wildlife: Practical Tips for Fencing with Wildlife in Mind. Wyoming Community Foundation, Laramie, WY. 56 pp.

**Patla, S. and D. Lockman. 2004.** Considerations and prescriptions for the design, construction and management of shallow water wetlands for spring through fall use by trumpeter swans (*Cygnus buccinator*) in western Wyoming. Report, Nov. 2004. Wyoming Game and Fish Department, Jackson, WY and Wildlife Services of the Rockies, Cheyenne, WY. 9 pp.

**Pollock, M.M., G. Lewallen, K. Woodruff, C.E. Jordan, and J.M. Castro, editors. 2015.** The Beaver Restoration Guidebook: Working with Beaver to Restore Streams, Wetlands, and Floodplains. Version 1.02. United States Fish and Wildlife Service, Portland, Oregon. 189 pp.

**Primm, S. B. Andrews, and A. Robinson. 2018.** Electrified Fladry For Deterrence of Gray Wolves (*Canis Lupus*): An Evolving Manual of Best Practices. People & Carnivores. 27 pp. Available online at: <http://peopleandcarnivores.org/>.

**Quitmeyer, C.J., J.A. Bopp, R.M. Stephens, R. Karhu and S. Anderson. 2004.** High-tensile electric fence: phase 2 – liability issues, maintenance costs, and containment of bison. Final Report December 2004. Wyoming Cooperative Fish and Wildlife Research Unit. Laramie, WY. 85 pp.

**Schmidt, L. and J. Knight. 2000.** Electric fencing to control deer and elk on Montana's farms and ranches. Montana State University Extension Service. 4 pp.

**Sheldon, D.P. 2005.** Movement and distribution patterns of pronghorn in relation to roads and fences in Southwestern Wyoming. Master's thesis, Department of Zoology and Physiology, University of Wyoming, Laramie, WY. 140 pp.

**Sowka, P. 2013.** Living with Predators Resource Guide Series—Practical Electric Fencing Resource Guide: Controlling Predators. Produced by the Living with Wildlife Foundation in cooperation with Montana Fish, Wildlife & Parks. 2013 edition. Arlee, Montana. Available online at: <https://lwwf.org/resource-guides>.

**Stevens, B.S. 2011.** Impacts of fence on greater sage-grouse in Idaho: collision, mitigation and spatial ecology. Master's thesis, College of Graduate Studies, University of Idaho, Moscow, ID. 210 pp.

**Stevens, B.S., J.W. Connelly and K.P. Reese. 2012a.** Multi-scale assessment of greater sage-grouse fence collision as a function of site and broad scale factors. *J. Wildlife Management*. doi: 10.1002/jwmg.397

**Stevens, B.S., K.P. Reese, J.W. Connelly, and D.D. Musil. 2012b.** Greater sage-grouse and fences: Does marking reduce collisions? *Wildlife Society Bulletin*. doi: 10.1002/wsb.142.

**Washington Dept. of Fish and Wildlife. 2004.** Make your fence wildlife friendly. *Crossing Paths Newsletter*, Fall 2004.

**Waterton Biosphere Reserve. 2015.** WBR Carnivores and Communities Technical Guide: Electric Fencing. Waterton Biosphere Reserve Carnivore and Communities Program, Pincher Creek, AB. 8 pp. Available online at: <http://www.watertonbiosphere.com>.

**Waterton Biosphere Reserve. 2015.** WBR Carnivores and Communities Technical Guide: Securing Your Grain Storage. Waterton Biosphere Reserve Carnivore and Communities Program, Pincher Creek, AB. 4 pp. Available online at: <http://www.watertonbiosphere.com>.

**Wolfe, D.H., M.A. Patten, and S.K. Sherrod. 2009.** Reducing Grouse Collision Mortality by Marking fences (Oklahoma). *Ecological Restoration* 27(2)141-143.

**Wyoming Game and Fish Dept. 2004.** Fencing guidelines for wildlife. Revised version. Habitat Extension Bulletin No. 53. Wyoming Game and Fish Dept. 12 pp.

**Yoakum, J. D., P. F. Jones, J. Cancino, R. J. Guenzel, R. Seidler, A. Munguia-Vega, I. Cassaigne, and M. Culver. 2014.** Pronghorn management guides. Fifth edition. Western Association of Fish and Wildlife Agencies' Pronghorn Workshop and New Mexico Department of Game and Fish, Santa Ana Pueblo, New Mexico. 159 pp.



Photo: ACA, Brad Downey



This guide was made possible by the Alberta Conservation Association and our partners.  
ACA conserves, protects, and enhances fish and wildlife populations and their habitats for Albertans to enjoy, value, and use.

